

May 3, 2024

**MAYOOR SCHOOL, AJMER**

1. This is with reference to the tender for Design, Supply, Installation, Testing & Commissioning of 100 kWp on Grid Connected Roof Top Solar PV (Photo Voltaic) Power Plant and net metering on the terrace of Senior School at Mayoora School, Alwar Gate, Ajmer.
2. Time for completion of the project will be 75 days from the date of acceptance of tender.
3. Tender fees of 500/- (Non-refundable) in cash and earnest money 2% of the quoted rate i.e. 78,000/- needs to be deposited in the form of DD in favour of Principal, Mayoora School, Ajmer at the time of submission of the tender failing which tender will not be considered for bid. Tender will be available for download on Mayoora School Website [www.mayoora-school.org](http://www.mayoora-school.org) from 04 May – 11 May 2024 at 5:00p.m.
4. In case of any query, you may contact Mr. Vijay Matange, Architect on the number 9810626130 and email id [vinyas.arch@gmail.com](mailto:vinyas.arch@gmail.com) or Mr. Vijendra Singh Tanwar, Junior Engineer, Mayoora School, Ajmer on mobile number 9680046651 and email id [office@mayoora-school.org](mailto:office@mayoora-school.org) between 10:00 am to 4:00pm.
5. Tender should be addressed to Principal, Mayoora School, Ajmer and submitted in sealed envelope by 10:00am on 13 May 2024 at the Administrative Office, Mayoora School, Ajmer delay in the submission of the tender would render the bid invalid.
6. Duly submitted tenders will be opened at Administrative Block on 13 May 2024 at 11:00am.

Sd/-

(PRINCIPAL)

*Design, Supply, Installation, Testing & Commissioning of 100 kWp on Grid Connected Roof Top Solar PV  
(Photo Voltaic) Power Plant and Net Metering on the terrace of Senior School  
Mayoor School, Alwar Gate, Ajmer.*

**INDEX**

<b>S NO.</b>	<b>DESCRIPTION</b>	<b>PAGES NO.</b>
I.	Notice Inviting Tenders.	1 - 2
II.	Instruction to Tenderers.	3 – 6
III.	Covering letter to the Tender.	7 – 8
IV.	Articles of Agreement.	9 – 10
V.	General Conditions of Contract.	11 – 32
VI.	Special Conditions of Contract.	33 - 34
VII.	Technical Specifications.	35 - 44
VIII.	List of Main Equipment and Approved Make Lists.	45
IX.	Specific makes & details.	46 - 47
X.	Appendix Showing Important Schedules.	48
XI.	Bill of Quantities	49
XII.	Diagram	50 - 51

**MAYOOR SCHOOL**

**TENDER FOR**

DESIGN, SUPPLY, INSTALLATION, TESTING & COMMISSIONING  
OF 100 KWP ON GRID CONNECTED ROOF TOP SOLAR PV (PHOTO VOLTAIC)  
POWER PLANT AND NET METERING

VOLUME – I: GENERAL & SPECIAL  
CONDITIONS OF CONTRACT

**CLIENT**

**MAYOOR SCHOOL, AJMER**

**ARCHITECTS**

**MR. VIJAY MATANGE**

**VINYAS**

Delhi

Email: [vinyas.arch@gmail.com](mailto:vinyas.arch@gmail.com)

## SECTION - 1

### NOTICE INVITING TENDERS

- 1 Sealed Item Rate Tenders are invited in the prescribed form by the Principal, Mayoora School, for the following:

Tender No.	Name of work	Tendered Value (in Rupees)	Earnest Money	Time of Completion (in months)
MS/Sol /2024	Design, Supply, Installation, Testing & Commissioning of 100 kWp on Grid Connected Roof Top Solar PV (Photo Voltaic) Power Plant on the terrace of Senior School at Mayoora School, Ajmer.	₹39.00 Lakh (Rupees Thirty Nine Lakh)	@ 2% of tender Price quoted	2.5 Months

- 2 Eligibility: The following eligibility criteria shall be complied to fulfill the Qualification Bid
- Average annual financial turnover in Grid Connected Roof Top Solar PV (Photo Voltaic) Power Plant on in the last three years should be at least 30% of the value of work as on 31.03.2018 (Please furnish the provisional balance sheet for the year 2017-18 if not audited).
  - During last seven years (ending on March 31st of the last completed Financial Year) should have successfully completed either
    - Three similar works each not less than 40% value of respective work (or)
    - Two similar works each not less than 50% value of respective work (or)
    - One similar work not less than 80% value of respective work.
- 3 The works, as detailed in this tender, shall be executed and completed in all respects within a period of from the date of the written order to commence the work in accordance with the Tender Documents, Instructions to Tenderers, General & Special Conditions of Contract, Bill of Quantities and Drawings to the satisfaction of the Architect.
- 4 The Tenderer is required to deposit **Rs. 78,000.00 (Rupees Seventy Eight Thousand only)** as earnest money along with the tender in the form of Bank Draft on Ajmer Branch of any Nationalised Bank in favour of the **PRINCIPAL, MAYOORA SCHOOL, AJMER**. The tender which is not accompanied with Earnest Money shall be summarily rejected. The earnest money of unsuccessful Tenderer(s) will be returned to the Tenderer if his tender is not accepted but without any Interest/Bank Commission/ Collection Charges within **30** days from the date of acceptance/finalisation of the tender.
- 5 Tender fees of ₹ 500/- (Non-refundable) in cash and earnest money 2% of the quoted rate i.e. ₹78,000/- needs to be deposited in the form of DD in favour of Principal, Mayoora School, Ajmer at the time of submission of the tender failing which tender will not be considered for bid. Tender will be available for download from the School Website i.e. [www.mayoora-school.org](http://www.mayoora-school.org) from 04-05-2024 to 11-05-2024 by 5:00 p.m.
- 6 Tenders in prescribed form duly accompanied with Earnest Money should be submitted in sealed cover superscribed with the name of the work and must reach the office of the Principal, Mayoora School, Ajmer, **latest by 10.00 hrs on 13-05-2024**
- 7 The Tenders shall remain valid for a period of **120 days** from the date of opening of the tender.
- 8 The total amount of the Security Deposit shall be 10% (Ten percent) of the total value of the contract for the work. The Earnest Money deposited shall be converted as initial Security Deposit in the case of successful tenderer. The balance of the Security Deposit would be made up by deduction of 10% (Ten percent) from the amount of each running/on account bill for the work done under the contract after adjusting initial deposit as mentioned earlier. No interest shall be paid on the said Security Deposit.

- 9 The Earnest Money of the successful tenderer shall be forfeited in the event of refusal or delay on his part in signing the Agreement within **7 days** of the of letter of award of the contract or refusal to start the work on instructions from the Architect/Engineer.
- 10 The Principal, Mayoor School, does not bind itself to accept the lowest or any Tender and reserves to itself the right to negotiate, accept or reject any or all the tenders either in whole or in part without assigning any reasons for doing so. Principal, Mayoor School, can bifurcate the works seeing the feasibility of execution/ early completion of works.

## SECTION – 2

### INSTRUCTIONS TO TENDERERS

2.1 The tenderers shall examine carefully all the tender documents consisting of:

- I. Notice inviting tenders.
- II. Instructions to tenderers.
- III. Tenderer's forwarding letter
- IV. Form of Agreement.
- V. General conditions of contract
- VI. Special conditions of contract.
- VII. Technical specifications & Drawings.
- VIII. Bill of quantities/Tender Schedule

The tenderer is advised to visit and inspect the site at his own cost and responsibility and to secure all necessary information which may be required for completing the work. Ignorance of site conditions or local information shall not be considered as an excuse for non-performance of the contract. All costs, charges and expenses that may be incurred by the Tenderer in connection with preparation of his tender shall be borne by him and Principal, Mayoora School, will not accept any liability whatsoever in this regard.

2.2 Time is the essence of the contract, and the Tenderers are required to complete the work in all respects within **75 Days** from the date of issue of letter of intent/order and hand over the same complete in all respects to the satisfaction of Architect.

2.3 The Tenderer shall use only the Form issued with this tender to fill up the rates.

2.3.1 Every page of the tender shall be signed on the left-hand side bottom corner and any tender not so complied with is liable to be treated as defective.

2.3.2 The Tender Form must be filled in English and all entries must be made by hand in ink. If any of the documents is missing, or unsigned, the tender is liable to be treated as defective tender.

2.3.3 Tenders not properly filled, mutilated with incorrect calculations, or generally not complying with the conditions are liable to be rejected.

2.3.4 Any erasures and alterations made while filling the tender must be attested by initials of the Tenderer. Over-writing of figures is not permitted. Failure to comply with either of these conditions will render the tender liable for rejection.

2.4 A schedule of approximate quantities for various items accompanies this tender. It must be definitely and clearly understood that this schedule is liable to alteration by omissions, deductions or additions to any extent at the discretion of Principal, Mayoora School, without affecting the terms of the contract.

2.4.1 The scope of work may be reduced or increased on either side due to variation in the space required to be constructed.

2.4.2 It shall be clearly understood that the rates quoted in the tender are for complete work at site as per Instructions to Tenderers, Conditions of Contract, Specifications, Schedule of Quantities and drawings, addenda referred to therein and for all such works as are necessary for the proper completion of the contract.

2.4.3 The tender should contain not only the rates but also the value of each item of work entered in the prescribed column of the schedule of quantities and all the items should be totaled up in order to show the aggregate value of the entire tender. The rates quoted by the Tenderer should be expressed accurately both in words and figures so that there is no discrepancy. The item rates quoted by the Tenderer in words and figures (whichever are lower) will be the basis (and not the amounts in case of discrepancies) in finalising the tender.

2.4.4 No alteration which is made by the tenderer in the Notice of Tender, Instructions to the Tenderer, Agreement Form, General and Special Conditions of Contract and Drawings, etc. accompanying the same shall be recognised, and if any such alterations are made, the tender is liable to be rejected.

2.5 The tender for the work shall remain open for acceptance for a period of **7 days** from the date of opening of the tender. If any tenderer withdraws his offer before the said period or makes any modifications in the terms and conditions of the tender, then Principal, Mayoor School, shall, without prejudice to any other right or remedy, be at liberty to forfeit the Earnest Money of the tenderer.

2.6 The Principal, Mayoor School, does not bind itself to accept the lowest or any tender and reserves to itself the right to accept or reject any or all the tenders/offers either in whole or in part without assigning any reasons for doing so.

2.7 Canvassing in connection with the tenders is strictly prohibited and the tenders submitted by the contractors who resort to canvassing will be liable to rejection.

**2.8 Rates must be quoted for complete work at site. The rates shall include the impact of Royalty, Toll Tax, Excise duty, Goods and Service Tax including adjustment of the set-off against GST availed, Labour Welfare Cess or any other taxes levied or leviable by Central or State Governments or by any local Authorities/Bodies. No part of such taxes on the contractor's labour or material shall be paid by the Employer who shall not entertain any claim whatsoever in this regard. The decision of the Employer in this regard shall be final and binding.**

**Any prevalent govt. subsidies or those available in the future during the implementation of the contract as availed by the tenderer shall be passed on to the Employer. All liaison and costs thereof incurred towards the same shall be the sole responsibility of the tenderer.**

**GST at prevalent rate will be paid over and above value of work. Necessary documentation with regard to GSTIN and proof of deposit of GST and Labour Cess may be required by the school before the GST and Labour Cess components of the bill(s) are released.**

2.8.1 Any new tax or any increase in rates of levies/taxes on the finished work introduced by Central or State Government or by any local authorities after the opening of the tender, shall be reimbursed to the contractor only on production of certificates from concerned authorities with authenticated documents to the fact that the same has already been deposited by the contractor. The contractor shall also be required to submit an undertaking for any kind of liability of the labour engaged in this project. Any abolition of tax or decrease in rates of levies/taxes on the finished work introduced by Central or State Government or by any local authorities after the opening of the tender, shall be recovered by Principal, Mayoor School, from running/on-account bills of the Contractor.

2.9 The contractor's operations and proceedings in connection with the work shall at all times be conducted during the continuance of the contract in accordance with the laws, ordinance, rules and regulations for the time being in force and the contractors shall further observe and comply with the bye- laws and regulations of the Government of India, State Government and Municipal and other authorities having jurisdiction over the area involved in connection with the works or site and over operations such as those as carried out by the contractor and shall give all notices required by such bye-laws and regulations.

2.10 The Agreement for this acceptance shall be executed on a non-judicial stamp paper of requisite value for which the stamp duty shall be borne by the Contractor.

2.11 Deduction towards Income Tax and works tax as per rules shall be made by Employer from the contractor's bills.

**2.12 Unknown/Indefinite Liabilities:**

Tenders containing any conditions leading to unknown/indefinite liabilities are liable to be rejected. If at all any rebate(s) is/are to be offered, the Tenderer shall first quote his rates strictly on the terms and conditions stipulated in the tender documents and then show separately any rebate(s) offered specifying the conditions for such rebate(s), if any.

2.13 List of documents to be submitted with the tender:

- (i) Tender with earnest money in sealed cover, superscribed "Tender for **Design, Supply, Installation, Testing & Commissioning of 100 kWp on Grid Connected Roof Top Solar PV (Photo Voltaic) Power Plant on the terrace of Senior School at Mayoor School, Ajmer** should reach the Principal, Mayoor School, not later than **10.00 hrs on 13-05-2024** Principal, Mayoor School, shall not accept any loss or delay in transit as an excuse for delayed/late tendering.
- (ii) Tender documents will be submitted along with detailed programme and targets of completion of each item of work.
- (iii) Details of deployment of manpower, machinery, plant and equipment.
- (iv) Income Tax Clearance Certificate
- (v) Partnership Deed and Articles of Association etc. as applicable.
- (vi) Power of Attorney
- (vii) List of works executed in last three years of value more than Rs. Fifty Lakhs with following details:

Name of Work	Value of Work	Client's Name and address	Period of Construction	
			As per Contract	As executed

Note: The client's certificate of completion of works in each case shall be furnished.

- (viii) List of all works in hand irrespective of monetary limit with following details:

Name of Work & Client's Name and address	Value of Work	Work Completed Upto <b>31.03.2024</b> (Financial Value)	Anticipated outlay <b>2024-25</b>	Anticipated outlay <b>2025-2026</b>

Note: The client's certificate of award of the works & work completed in each case shall be furnished.

- (ix) Turnover of the firm in last 3 years, duly supported by I.T.C.C. (Attested copies) or any other document acceptable, for year.
- (x) Solvency certificate from banker for last one year.
- (xi) Details of registration with State Government and Semi-Government authorities with documentary proof.
- (xii) Arbitration cases, if any, during the last three years.
- (xiii) Any other information the tenderer wants to give.



#### 2.14 MODE OF SUBMISSION OF TENDER

The tenderer are required to submit their offer in the following manner:

1. Envelope marked "Number 1 – Earnest Money" shall contain the Earnest money deposit
2. Envelope marked "Number 2 –Techno-commercial Bid" shall contain technical data or other information as stated below:
  - a. Covering letter to the tender
  - b. Any comments which the tenderer desires to make in the form of a statement, as brief as possible and with proper reference to the items, clauses and pages of the tender documents to which the comments pertain.
  - c. Documents as per **clause 2.13.**
  - d. Book-let superscribed "**Tender documents – Part-I "Design,Supply, Installation, Testing & Commissioning of 100 kWp on Grid Connected Roof Top Solar PV (Photo Voltaic) Power Plant on the terrace of Senior School at Mayoor School, Ajmer"**".
3. Envelope marked "Number 3 – Price Bid" shall contain only the price bid on the tender booklet superscribed "**Tender documents - Part-II (Price-Bid) "Design,Supply, Installation, Testing & Commissioning of 100 kWp on Grid Connected Roof Top Solar PV (Photo Voltaic) Power Plant on the terrace of Senior School at Mayoor School, Ajmer"**", in a prescribed manner and must be sealed.
4. Envelopes marked number 1, 2 and 3 shall be put in a large envelope of adequate size. It shall be sealed and marked to the Principal, Mayoor School. The full name and address of the Tenderer and the name of the work shall be written on the cover.

#### 2.15 ACCEPTANCE OF TENDER

Principal, Mayoor School, reserves the right to reject any or every tender without assigning any reason whatsoever and or to negotiate with the tender(s) in any manner the Principal, Mayoor School, considers suitable.

**SECTION – 3**  
**(Covering Letter to the Tender)**

FROM  
M/s .....

Date:

To,  
**Principal,**  
**Mayoor School,,**  
**Ajmer**

**Ref: Design,Supply, Installation, Testing & Commissioning of 100 kWp on Grid Connected Roof Top Solar PV (Photo Voltaic) Power Plant on the terrace of Senior School at Mayoor School, Ajmer.**

Dear Sir,

With reference to the tender invited by you, I/We hereby offer to perform, provide, execute and complete the works in conformity with the conditions of contract, drawings and specifications for the respective items of schedule of quantities attached hereto.

1. I/We have satisfied myself/ourselves as to the location and prevailing conditions of the site, and have read carefully the tender booklet(s) containing Articles of Agreement, conditions of Contract, Specifications, General and Special Conditions, Drawings etc. and I/We understand that the works are to be completed within **75 days** from the date of issue of Letter of Intent/Order and fully understand that the time will be the essence of the contract.
2. I/We enclose a demand draft for **the amount of Rs. \_\_\_\_\_/- (Rupees \_\_\_\_\_ only) as per clause no. 1.3 of Notice Inviting Tenders**, drawn on \_\_\_\_\_, payable in favour of \_\_\_\_\_ as Earnest Money and fully understand that this amount will not bear any interest.
3. I/We agree to keep the offer open for **7 days** from the date of opening of the tender.
4. Should this tender be accepted in whole or in part, I/We hereby agree to abide by and fulfill all the terms and conditions annexed hereto. If I/We fail to commence the work specified in tender documents, I/We agree that my/our earnest money shall stand forfeited absolutely to the Employer otherwise the said Earnest Money shall be retained by the Employer towards Security Deposit (retention money). I/We also agree to the balance security money being deducted from my/our bills in accordance with the conditions of the contract.
5. All the terms and conditions contained in the Notice Inviting Tenders, General & Special Conditions of Contract, Specifications, for execution of work and additional conditions and the Agreement etc. constituting the tender documents have been fully read by me/us and explained to me/us and I/We hereby accept the same and sign hereunder in token of their acceptance.
6. We are further enclosing herewith the following documents:
  - (i) Partnership deed, Articles of Association and Power of Attorney. We agree that no change will be made in these documents without prior approval of Principal, Mayoor School.
  - (ii) Tender Documents duly signed along with detailed programme and targets of completion of each item of work.
  - (iii) Details of deployment of manpower, machinery, plant and equipment. Total list of plants and machinery in possession of the firm and the list of plant and machinery which will be exclusively deployed on this work.
  - (iv) Latest Income Tax Clearance Certificate.
  - (v) Draft No. \_\_\_\_\_ dated \_\_\_\_\_.**2020**. drawn on \_\_\_\_\_.

(vi) Name of Proprietor/Director/Partners of the firm: .....  
Yours Faithfully

**Name and Signature of Tenderer**

**M/s** .....

.....

**Office stamp & seal of Tenderer(s)**

Date: \_\_\_\_\_

Witness: \_\_\_\_\_

Address: \_\_\_\_\_

Occupation: \_\_\_\_\_

## SECTION – 4

### ARTICLES OF AGREEMENT

Articles of agreement made this day \_\_\_\_ of \_\_\_\_\_ **20** between Principal, Mayoor School, having its registered office at \_\_\_\_\_ (hereinafter referred to as "Employer" which expression shall mean and include its successor in office executor, administrator assignees) of the one part and **M/s** \_\_\_\_\_ having its office at \_\_\_\_\_, hereinafter referred to as "contractor", which expression shall include his heir, executor, administrator and assignees) of the other part. Whereas the Employer is desirous of getting **Design, Supply, Installation, Testing & Commissioning of 100 kWp on Grid Connected Roof Top Solar PV (Photo Voltaic) Power Plant on the terrace of Senior School at Mayoor School, Ajmer.** and has caused drawings, specifications and schedule of quantities describing the works to be done, to be prepared by the Employer and whereas the said drawings issued by the Employer from time to time, and notice inviting tenders, instructions to Tenderers, general and special conditions of contract, technical specifications and schedule of quantities have been signed by or agreed to execute upon and subject to the conditions set-forth herein (hereinafter referred to as the said conditions) and the Special Conditions and specifications of the work shown upon the said drawings and/or described in the said specifications and included in the said schedule of quantities at rates therein set-forth amounting to the sum of **Rs.** \_\_\_\_\_ (**Rupees** \_\_\_\_\_ **only**) hereinafter referred to as "the said contract amount". And whereas the contractor has deposited with the Employer the sum of **Rs.** \_\_\_\_\_ (**Rupees** \_\_\_\_\_ **only**) as the earnest money which shall become part of security deposit to be retained until the expiry of the defects liability period for the due observance and performance of this contract.

#### Now it is hereby agreed as follows:

1. In consideration of the said contract amount to be paid at the times and in the manner set-forth in the said conditions, the contractor shall, upon and subject to the said conditions execute and complete the work shown upon the said drawings and described in the said specifications and/or the schedule of quantities and other conditions and within **75 Days** of the date of commencement of the work the latest day by **\_\_ . \_\_ . 20\_\_**.
2. The commencement of work will be taken as the date of issue of the letter of intent/order for award of the contract.
3. The contractor clearly understands that the time is the essence of the contract, and penalty will be imposed for delay in execution of the work, as per the terms of the contract.
4. The Employer shall pay to the contractor the said contract amount or such other sum as shall become payable at the times as hereinafter specified in the conditions.
5. The following documents shall be deemed to form and be read and construed as part of the agreement along with the amendments, negotiated and confirmed in various subsequent letters exchanged as mentioned hereinafter.
  - (i) Notice inviting tenders.
  - (ii) Instructions to tenderers.
  - (iii) General conditions of contract.
  - (iv) Special conditions of contract.
  - (v) Technical specifications.
  - (vi) Schedule of quantities.
6. Employer's letter No. \_\_\_\_\_ dated \_\_\_\_\_ to the contractor for awarding the contract.

7. Contractor's letter No. \_\_\_\_\_ dated \_\_\_\_\_ to the Employer in acceptance of the award of contract.

8. Drawings

The parties hereto shall respectively abide by submitting themselves to the conditions and perform the agreement on their part respectively in such conditions contained.

As witness our hands this \_\_\_\_\_ day of \_\_\_\_\_ **20**\_\_.

1. Signed by the said

2. Signed by the said

Employer (First Party)

Contractor (Second Party)

\_\_\_\_\_

M/s \_\_\_\_\_

Principal, Mayoor School,

\_\_\_\_\_

In the presence of

In the presence of

\_\_\_\_\_

\_\_\_\_\_

Address

Address

\_\_\_\_\_

\_\_\_\_\_

\_\_\_\_\_

\_\_\_\_\_

## SECTION - 5

### GENERAL CONDITIONS OF CONTRACT

- I. Definitions and interpretations
- II. General obligations
- III. Execution of works
- IV. Variations in extent of contract
- V. Measurements, Certificates and Payments
- VI. Labour
- VII. Claims
- VIII. Determination of Contract
- IX. Settlement of Disputes

#### I. Definitions and Interpretations

5.1. Definitions: In these general conditions of contract, the following terms shall have meaning hereby assigned to them except where the context otherwise requires:

- a) "Employer" shall mean the Principal, Mayoora School, or any other Committee/representative acting on his behalf and includes their authorized representative to deal with any matters on their behalf.
- b) "Engineer" shall mean "Chief Project Manager" who shall be accredited representative of the Employer at site.
- c) "Engineers representative" means any Engineer or assistant appointed from time to time by the Employer.
- d) "Architect" means appointed by the Employer or their representative to act on their behalf in connection with the execution of the project.
- e) "Contractor" shall mean the persons or company whether incorporated or not who enter into the contract with the Principal, Mayoora School, and shall include their heirs, executors, administrators, successors and permitted assignees.
- f) "Contract" shall mean and include the notice inviting tenders, the letter of intent, the agreement and work order, the accepted schedule of rates and quantities, the general conditions of contract, special conditions of contract, drawings, and specifications (if any) including all the modifications thereof incorporated in their execution.
- g) "Works" shall mean the works to be executed in accordance with the contract.
- h) "Specifications" shall mean the standard specifications for works and materials of the Employer and specifically brought out in the notice inviting the tender, as amplified added to, or superseded by special specifications and embodied in the contract. In absence of any specifications for any item of the work, the relevant specifications in PWD BSR Ajmer Circle and IS Code shall be followed in that order and work shall be executed accordingly.
- i) "Drawings" shall mean the maps, drawings, plans and tracing or prints thereof annexed to the contract and shall include any modification of such drawings and further drawings as may be issued by the Architect from time to time.
- j) "Constructional Plant" shall mean all appliances or things of whatsoever nature required for the execution, completion or maintenance of the works or temporary works (as hereinafter defined) but does not include materials or other things intended to form or forming part of the permanent work.
- k) "Temporary Work" shall mean all temporary works of every kind required for the execution, completion or maintenance of the works.
- l) "Site" shall mean the lands and other places on, under, in or through which the works are to be carried out and any other lands or places provided by Principal, Mayoora School, for the purpose of the contract.

- m) "Period of maintenance" shall mean the specified period of maintenance from the date of completion of the works, as certified by the Architect/Engineer.
- n) "Hindrance Register" shall mean the register maintained at the site of work showing the item affected, the date on which the delay occurred and the date on which the delay was cleared and reason for delay. These entries shall be signed by the contractor, Employer/Engineer or their authorised representative.
- o) "Virtual Completion": Virtual completion shall mean that the works are completed in all respects and fit for use in every respect including installation of all services complete in working order to the full satisfaction of the Architect and the Owner.
- p) Definitions of Time
  - i. "A day" shall mean a day of 24 hours from midnight to midnight irrespective of number of hours worked in that day.
  - ii. "Normal working hours" shall mean 9 (nine) hours per day. The specific timing would vary depending upon the season.
  - iii. "A week" shall mean 7 (seven) days without regard to the number of hours worked in any day in that week.
  - iv. "A Month" shall mean a calendar month without regard to the number of days in that month.

5.1.1 "Singular and Plural" words imparting the singular number shall also include the plural and vice versa where the context so requires.

5.1.2 "Headings and marginal headings":

The headings and marginal headings in these general conditions are solely for the purpose of facilitating reference and shall not be deemed to be part thereof or be taken into consideration in the interpretation or construction thereof or of the contract.

## b) GENERAL OBLIGATIONS

### 5.2 Intent & Scope of Contract:

5.2.1 The intent of the contract is that the Contractor shall provide Grid Connected Roof Top Solar PV (Photo Voltaic) Power Plant and/or systems in complete functioning order and all work or materials necessary for the above intent shall be deemed to be included and all items will be paid for at the rates established in the Contract.

5.2.2 The Contractor shall supply at his own cost all materials, plants, tools, appliances, implements, ladders, cordage, tackles, scaffolding, shuttering and temporary works required for the proper execution of the work whether original, altered or substituted and whether included in the specification or other documents forming part of the contract or referred to in these conditions or not or which may be necessary for the purpose of satisfying the conditions or as directed by the Engineer or his representatives at the site of work.

5.2.3 The Contractor shall also provide all necessary fencing and lights required to protect the public from accident, and shall be bound to bear the expenses of defense of every suit, action or other proceedings at law that may be brought by any person for injury sustained owing to the neglect of the above precautions and to pay any damages and costs which may be awarded in such suits, actions or proceedings to any such persons or which may with the consent of the Contractor be paid to compromise any claim by any such person. In no case, the Employer shall be a party to any such claim/claims.

### 5.2.4 Sufficiency of tender:

The Contractor shall be deemed to have satisfied himself before tendering as to the correctness and sufficiency of his Tender for the work and of the prices stated in the schedule which shall except in so far as it is otherwise provided in the contract, cover all his obligations under the contract and all matters and things necessary for the proper completion, functioning and maintenance of the work.

### 5.2.5 Law Governing the Contract:

The Contract shall be governed by the law for the time being in force in the country. The Contractor when called upon to do so shall enter into and execute the Contract Agreement with the Employer. The Contract Documents are complimentary and what is called for by any one shall be binding as if called for by all.

### 5.2.6 Compliance to Regulations and Bye-Laws:

The Contractor shall conform to the provisions of any Statutes relating to the works and Regulations and Bye- Laws of any local authority and of any water and lighting companies or undertakings with whose system the work is proposed to be connected and shall before making any variations from the drawings or the specifications that may be necessitated by so conforming, give to the Engineer notice specifying the variations proposed to be made and the reasons for making the variations and shall not carry out such variation until he has received instructions from the Engineer in respect thereof. The Contractor shall be bound to give all notices required by statutes, Regulations or Bye-Laws as aforesaid and to pay all fees and taxes payable to any Authority in respect thereof.

### 5.2.7 Communications to be in writing:

All notices, communications references and complaints made to Employer or the Engineer or the Engineer's representative or the Contractor concerning the works shall be in writing and no notice, communication, reference or complaint not in writing shall be recognised.

### 5.2.8 Service of notice on Contractor:

The Contractor shall furnish to the Engineer the name, designation and address of his authorized agents and all complaints, notices, communications and references shall be deemed to have been duly given to the Contractor if delivered to the Contractor or his authorised agents or left at or posted to the address so given and shall be deemed to have been so given in the case of posting on the day on which they would have reached such address in the ordinary course of post or on the day on which they were so delivered or left.

### 5.2.9 Constitution of Firm:

The Tenderer(s) who is/are constituents of the Firm, Company, Association or Society must forward attested copies of the constitution of their concern, partnership deed and power of attorney with their tender. Tender Documents in such cases are to be signed by such person as may be legally competent to sign them on behalf of the Firm, Company, Association or Society as the case may be. Co-operative



societies must likewise submit an attested copy of their certificate of registration along with the documents as aforementioned. The EMPLOYER will not be bound by any power of attorney granted by the Tenderer(s) or by changes in the composition of the Firm made subsequent to the execution of the Contract. EMPLOYER may, however, recognize such power of attorney and changes after obtaining proper legal advice, the cost of which will be chargeable to the Contractor. If the Tenderer expires after the submission of his tender or after the acceptance of his tender, EMPLOYER shall deem such Tender/Contract as cancelled. If a partner of the firm expires after the submission of their tender, EMPLOYER shall deem such tender as cancelled unless the firm retains its character. If the Contractor's firm is dissolved on account of death, retirement of any partners or for any reason whatsoever, before fully completing the whole work or any part of it, undertaken by the Principal Agreement, the surviving partners shall remain jointly/severely and personally liable to complete the whole work to the satisfaction of EMPLOYER due to such dissolution. The cancellation of any documents such as power of attorney, partnership deed, etc. shall forthwith be communicated to EMPLOYER in writing, failing which EMPLOYER shall have no responsibility or liability for any action taken on the strength of the said documents.

#### **5.2.10 Occupation and use of land:**

No land belonging to or in possession of the EMPLOYER shall be occupied by the Contractor without the permission of EMPLOYER. The Contractor shall not use, or allow to be used, the site for any purpose other than that of executing the works. The equipment and material shall be removed from the site after installation of Grid Connected Roof Top Solar PV (Photo Voltaic) Power Plant so that the area is available for the other development works. **In case of failure to keep the site clear as mentioned above a penalty @ Rs.50/- per sq.m. per month will be levied**, without prejudice to other rights and remedies.

#### **5.2.11 Assignment or sub-letting of Contract:**

The Contractor shall not assign or sublet the Contract or any part thereof or allow any person to become interested therein in any manner, whatsoever, without the special permission of the EMPLOYER. Any breach of this condition shall entitle the EMPLOYER to rescind the Contract under clause 5.8.2 (v) of these conditions and also render the Contractor liable for payment to EMPLOYER in respect of any loss or damage arising or ensuing from such cancellation. Provided always that execution of the details of the work by petty contractor under the direct and personal supervision of the Contractor or his agent shall not be deemed to be subletting under this clause. The permitted subletting of work by the Contractor shall not establish any contractual relationship between the sub-contractor and EMPLOYER and shall not relieve the Contractor of any responsibility under the Contract.

#### **5.2.12 Representation on works:**

The Contractor shall, when he is not personally present on the site of the works, place and keep a responsible agent at the works during working hours who shall on receiving reasonable notice, present himself to the Engineer and orders given by the Engineer or the Engineer's representative or Architect to the agent shall be deemed to have the same force as if they had been given to the Contractor. Before absenting himself, the Contractor shall furnish the name and address of his agent for the purpose of this clause. Such agents shall not be changed and shall not leave during the duration of the Contract unless the consent of the Engineer have been previously obtained. Any failure on the part of the Contractor to comply with this provision at any time will entitle the EMPLOYER to levy a penalty of Rs.10,000/- per month or rescind the Contract under clause 5.8.2 of these conditions.

#### **5.2.13 Relics:**

All gold, silver, oil and other minerals of any description and all precious stones, coins, treasure, relics, antiquities and other similar things which shall be found in or upon the site shall be the property of EMPLOYER and the Contractor shall duly preserve the same to the satisfaction of EMPLOYER and shall from time to time deliver the same to such person or persons as EMPLOYER may appoint to receive the same.

#### **5.2.14 Plant Materials:**

The Contractor shall not sell or otherwise dispose of or remove except for the purpose of this Contract, the said material used for Design, Supply, Testing, Installation and Commissioning of 100 kWp Grid Connected Roof Top Solar PV (Photo Voltaic) Power Plant Indemnity by Contractor:

The Contractor shall indemnify and save harmless EMPLOYER from and against all actions, suits, proceedings, losses, costs, damages, charges claims and demands of every nature and description brought or recovered against EMPLOYER by reason of any act or omission of the Contractor, his agents or employees, in the execution of the works or in the guarding of the same.

All sums payable by way of compensation under any of these conditions shall be considered as reasonable compensation to be applied to the use of EMPLOYER without reference to the actual loss or damage sustained and whether or not any damage shall have been sustained.

#### **5.2.15 Earnest Money and Security Deposit:**

Every Tenderer shall deposit along with his tender an Earnest Money as indicated in the Notice Inviting Tender in the form of Bank Draft payable at Ajmer Branch of any Nationalised Bank in favour of Principal, Mayoor School, The Earnest Money deposited by the successful Tenderer shall be converted to form part of the Security Deposit to be paid by the successful Tenderer. In case the Tenderer withdraws his offer before the expiry of his validity period of 120 days or if the tender is accepted by EMPLOYER, but the Tenderer does not sign the necessary Contract Agreement within seven days of issue of letter of intent/order or refuses to start the work on instructions from Architect/Engineer, the Earnest Money so deposited, shall stand forfeited to EMPLOYER.

#### **5.2.16 Refund of Earnest Money:**

The Earnest Money of the unsuccessful Tenderer(s) shall be refunded without any interest/Bank Commission/Collection charges within **60 Days** of the acceptance/finalisation of the Tender.

#### **5.2.17 Payment of Security Deposit:**

- (i) On receipt of the Letter of Intent/Order, the successful Tenderer shall pay Security Deposit on the scale mentioned thereunder for the due and faithful fulfillment of the Contract. The total amount of the Security Deposit shall be 10% (Ten percent) of the total value of the contract for the work. The Earnest Money deposited shall be converted as initial Security Deposit in the case of successful tenderer. The balance of the Security Deposit would be made up by deduction of 10% (Ten percent) from the amount of each running/on account bill for the work done under the contract after adjusting initial deposit as mentioned earlier. No interest shall be paid on the said Security Deposit. However, As soon as the Security Deposit so deducted from running/on account bills amounts to one half of the total security deposit due, the Contractor will, on production of a Bank Guarantee from any Nationalised Bank for an amount equal to one quarter of the total security deposit due valid till 30 days of expiry of maintenance period be entitled for a refund of an amount equal to one quarter of the total security deposit due. Thus keeping an amount equal to one quarter of the total security deposit due in cash as security deposit which shall be retained till 30 days of expiry of maintenance period Subsequent security deposit deducted from running/on account bills, i.e., balance of an amount equal to one half of the total security deposit due can be converted into two bank guarantees, each of an amount equal to one quarter of the total security deposit due, whenever the amount of security deposit deducted reaches an amount equal to one half of the total security deposit due. These two subsequent bank guarantees of an amount equal to one quarter of the total security deposit due each shall remain valid till three months of the completion of the entire work.
- (ii) Alternatively, at the start of a contract, contractor can furnish three bank guarantees from Nationalised bank of equal amount amounting to an amount equal to one quarter of the total security deposit due each. Two bank guarantees should be valid till three months of the completion of the entire work and the other one should be valid till 30 days of expiry of maintenance period. In such cases, balance amount will be deducted from running on account bills towards security deposit only upto an amount equal to one quarter of the total security deposit due in cash, which shall be retained till 30 days of expiry of maintenance period.

#### **5.2.18 Refund of the Security Deposit:**

- (i) On faithful completion of the contract one half of the Security Deposit shall be refunded to the Contractor within **180 days** of the completion of the entire work, subject to the issue of a completion certificate by the Architect/Engineer. However, refund of part of the Security Deposit shall not relieve the Contractor from his obligations and liabilities to make good any defects, imperfections, shrinkage of faults which may appear during the period of maintenance specified in the Contract. In case Contractor has furnished Bank Guarantee(s), the Bank Guarantee(s), valid till three months of the completion of the entire work and amounting to one half of the Security Deposit will be released within 180 days of the completion of the entire work subject to the issue of completion certificate by the Architect/ Engineer.

- (ii) The balance half of the Security Deposit shall become due and shall be paid to the Contractor after 30 days of the expiry of the period of maintenance, handing over of external development works to local authorities satisfactorily, and issue of certificate of completion comprising the whole of the works.
- (iii) Provided always that no Security Deposit shall become due nor shall be payable to the Contractor unless all the stipulations of the Contract have been fulfilled by the Contractor and all claims and demands made against the Employer for and in respect of damages or loss by firm or in consequences of the works, but excluding the claims made by the Contractor on the Employer have been finally satisfied.
- (iv) Security Deposit shall be liable to be forfeited by the Employer in the event of breach of Contract on the part of the Contractor, without prejudice to other rights and remedies.
- (v) Security Deposit shall be liable to be forfeited by the Employer in the event of breach of Contract on the part of the Contractor, without prejudice to other rights and remedies.

**5.2.19 Interest on amount:** No interest shall be payable on the Earnest Money or the Security Deposit or any amount payable to the Contractor under the Contract, except as provided for under the Conditions of this Contract.

**5.2.20 Illegal gratification:**

Any bribe, commission, gift or advantage given, promised or offered by or on behalf of the Contractor or his partner, agent or servant or any one of his or on their behalf to any officer, or employee of EMPLOYER or to any person on his or their behalf in relation to obtaining or execution of this or any other Contract with EMPLOYER shall, in addition to any criminal liability which he may incur subject the Contractor to the rescission of the Contract and EMPLOYER shall be entitled to deduct the amounts so payable from any money due to the Contractor under the Contract or any other Contracts with EMPLOYER. The Contractor shall not lend or borrow from or have or enter into any monetary dealings or transactions either directly or indirectly with any employee of EMPLOYER and if shall do so, EMPLOYER shall be entitled forthwith to rescind the Contract and all other Contracts with EMPLOYER. Any question or dispute as to the commission of any offence or compensation payable to EMPLOYER under this clause shall be settled by the CEO, Principal, Mayoora School, in such manner as he shall consider fit and sufficient and his decision shall be final and conclusive.

**5.2.21 Time Limitation:**

The time allowed for execution of the works or part of works as specified in the Contract Documents in accordance with these conditions shall be the essence of the Contract. Subject to any requirement in the Contract as to completion of any portion or portions of the works before completion of the whole of the work, the Contractor shall fully and finally complete the whole of the work comprised in the Contract (with modifications as may be directed under conditions of this Contract) by the date entered in the Contract or extended date.

**5.2.22 Date of Commencement and Completion:**

The Contractor shall be allowed admittance to the site on the Date of commencement" stated in the Appendix, and he shall thereupon and forthwith begin the works and shall regularly proceed with to complete the same (except such painting or other decorative works as the Engineer may desire to delay) on or before the "Day of Completion" stated in the Appendix subject nevertheless to the provisions for extension of time hereinafter contained.

**5.2.23 Accepted Programme of Work:**

As soon as the work is awarded, but not later than 7 days after the date of issue of letter of intent, the Contractor shall submit a detailed programme of work in the form of CPM/ PERT Network, BAR charts indicating the time schedule for commencement and completion of various items of works and the organisation in labour, plant and machinery that he intends to utilise for execution of the works, and complete the same by the stipulated dates of completion. The programme of work amended as necessary after discussions with the Engineer shall be treated as agreed programme for the purpose of this Contract and Contractor shall endeavour to fulfil this programme of work. Nothing stated herein shall preclude the Contractor in achieving earlier completion of the individual items or whole of the work than indicated in this programme.

**5.2.24 Delays & the Extension of Time:**

- i. If in the opinion of the Engineer, the works are delayed:
  - (a) by force MAJEURE or
  - (b) by reasons of any exceptionally inclement weather or
  - (c) by reason of proceedings taken or threatened by or dispute with adjoining or neighbouring owners or public authorities arising otherwise than through the Contractor's own default or

- (d) by the works or delays of other Contractors or Tradesmen engaged by the Employer and not referred to in the schedule of Quantities and/or Specifications or
  - (e) by reasons of Engineer's instructions or
  - (f) by reasons of civil commotion, local combination of workmen or strike or lock out affecting any of the traders or
  - (g) Inconsequent of the Contractor not receiving in due time necessary instructions from the Engineer for which he shall have specifically applied in writing, the Employer shall make a fair and reasonable extension of time for completion of the Contract works. In case of such strike or lockout, the Contractor should give immediately written notice thereof to Engineer, but the Contractor shall nevertheless constantly use his endeavours to prevent delays and shall do all that may reasonably be required to proceed with the work to the satisfaction of the Engineer.
- ii. The Contractor's right to an extension of time limit for completion of the work in the above-mentioned cases is subject to the following procedures:
- (a) That, within 10 days after the occurrence of case of force MAJEURE but before the expiry of the stipulated date of completion, he informs the Engineer in writing that he considers himself entitled to an extension of the time limit.
  - (b) That, he produces evidence of the date of occurrence and the duration of the force MAJEURE in an adequate manner by means of documents drawn up by reasonable authorities.
  - (c) That, he proves that the said conditions have actually interfered with the carrying out of the Contract.
  - (d) That, he proves that the delay incurred is not due to his own action or lack of action. In the cases mentioned above for delays in completion of works, such failures or delays shall in no way affect or vitiate the Contract or alter the character thereof or entitle the Contractor to damages or compensations thereof but the Contractor shall apply for extension of time at least 45 days before the completion of the Contract period and EMPLOYER shall grant such extension or extensions of the completion dates as shall appear to the Employer reasonable in the circumstances and his decision in the matter will be final and binding on the Contractor.
- iii. In all other cases EMPLOYER may grant extension of time with penalty, liquidated damages and without escalation.

**5.2.25 Liquidated Damages for Delay:** The time and date stipulated in the Contract for the completion of the work or any part or stage thereof shall be deemed to be the essence of the Contract. The work shall, throughout the stipulated period of Contract, be carried out with all diligence. If the Contractor fails to complete the work within the time prescribed or within the extended time under the Contract, he shall pay to EMPLOYER on demand without prejudice to other rights and remedies, EMPLOYER may have against the Contractor, a sum of **0.5%** of the contract value per week or part thereof as liquidated damages for such default, and not as a penalty for every week or part thereof after the stipulated date of completion, provided that the total liquidated damages payable shall not exceed **5%** of the Contract value. EMPLOYER may, without prejudice to any other method of recovery, deduct the amount of such damages from any moneys due or which become due to the Contractor. The recovery or deduction of such damages shall not relieve the Contractor from any obligations and liabilities under the Contract. During this period of delay, no escalation of prices shall be payable viz., original quoted rates will be paid.

**5.2.26 Failure by Contractor to Comply with Engineer's Instructions:**

If the Contractor after receipt of written notice from the Engineer requiring compliance within ten days fails to execute such works as per drawings or as per Engineer's instructions, the Engineer may employ and pay other persons to execute any such work, whatsoever, that may be necessary to give effect thereto, and all costs incurred in connection therewith including loss, if any, shall be recoverable from the Contractor by the Engineer as a debit or may be deducted by him from any money due or to become due to the Contractor.

**c) EXECUTION OF WORKS**

**5.3.0 Contractor's understanding:**

It is understood and agreed that the Contractor has by careful examination, satisfied himself as to the nature and location of the work, the configuration of ground, the character, quality of the materials to be encountered, the character of equipment and facilities needed preliminary and during the execution of

the works, the general and local conditions, the labour conditions prevailing therein and all other matters which can in any way affect the works under the Contract.

#### **5.3.1 Commencement of Works:**

The Contractor shall commence the works immediately after the receipt of order in writing to this effect from the Employer and shall proceed with the same with due expedition and without delay.

#### **5.3.2 Programme of work and Compliance to Engineers Instructions:**

The Contractor shall on receipt of the letter of intent/order or as soon as possible thereafter, but not later than **30 days** from the date of issue of letter of intent/order submit to Engineer for his approval, CPM, PERT and Bar Charts. The programme shall be prepared in such a manner that it shall have adequate float for the unforeseen items and additional works, if any, and also programme showing the order and procedure in which he proposes to carry out the work. The Contractor shall, whenever required by the Engineer, also provide in writing for his information general description of the arrangement and methods which the Contractor proposes to adopt for the execution of the work. If at any time it should appear to the Engineer that the actual progress of the work does not conform to the approved programme referred to above, the Contractor shall produce at the request of the Engineer, a revised programme showing the modification to the approved programme necessary to ensure timely completion of the Contract. The submission to and approval by the Engineer of such programmes or the furnishing of such particulars shall not relieve the Contractor of any of his duties or responsibilities or obligations under the Contract. The Employer or their representatives shall have full powers and authorities during progress of the work to issue such instructions as may be necessary for the proper execution of the work and the Contractor shall carry out and be bound by the same. In case the Contractor fails to submit the above referred programme charts or connected/modified programme charts, the Engineer will have the option to get these prepared at the cost of Contractor in addition to the levy of penalty which will be binding.

**5.3.3 Instructions of Engineer's Representatives:** Any instruction or approval given by the Engineer's representatives to the Contractor in connection with the works shall bind the Contractor as though it had been given by the Engineer provided as follows:

- (a) Failure of the Engineer's Representatives to disapprove any work or materials shall not prejudice the power of the Engineer thereafter to disapprove such works or materials and to order the removal or breaking up thereof.
- (b) If the Contractor shall be dissatisfied by reason of any decision of the Engineer's representative he shall be entitled to refer the matter to the Engineer who shall there upon confirm or vary such decision.

#### **5.3.4 Responsibilities for the Structural Adequacy:**

The Contractor shall comply with the provisions of the Contract and with due care and diligence, execute and maintain the work and provide all labour, including supervision of all works, structural plans and other things whether of temporary or permanent nature required for such execution and maintenance in so far as the necessity for providing these, is specified or is reasonably inferred from the Contract. The Contractor shall be fully responsible for the adequacy, suitability and safety at site of all the works and methods of the construction adopted.

#### **5.3.5 Supervision of Works:**

Provision of efficient and competent staff: The Contractor shall place and keep on the works at all time efficient, competent and qualified staff to give the necessary directions to his workmen and to see that they execute their work in sound and proper manner and shall employ only such supervisors, workmen and labourers in or about the execution of any of the works as are careful and skilled in their various trades and callings. The Contractor shall at once remove from the works any agent, permitted subcontractor, supervisor, workmen or labourer who shall be objected to by the Engineer and if and whenever required by the Engineer, he shall submit a correct return showing the names of all staff and workmen employed by him. In the event of the Engineer being of the opinion that the Contractor is not employing on the works sufficient number of staff and workmen as is necessary for the proper completion shall forthwith on receiving intimation to this effect take on the additional number of staff and labour specified by the Engineer within seven days of being so required and failure on the part of the Contractor to comply with such instructions still entitle EMPLOYER to levy penalty or rescind the Contract under relevant provisions of these conditions.

**5.3.6** The Contractor shall employ at site at his own cost at least one full-time Civil Engineering diploma Engineer with a minimum experience of 7 years in carrying out similar types of work with adequate number of Assistants. The name, qualifications, and experience of the Engineer proposed to be employed by the Contractor shall have to be approved from the Engineer before the commencement of

the work. A penalty of Rs.10,000/- per month shall be recoverable from the Contractor for Non- compliance of this clause. Continued noncompliance of Engineer's instructions shall amount to breach of the Contract by the Contractor who shall be solely responsible for all the consequences arising therefrom, without prejudice to other rights and remedies.

#### **5.3.7 Other Works:**

Separate Contracts in connection with works: EMPLOYER shall have the right to allot other Contracts in connection with the works. The Contractor shall afford other Contractors a reasonable opportunity for the storage of their materials and the execution of their work and shall properly connect and co-ordinate his work with theirs. If any part of the Contractor's work depends for the proper execution or results upon the work of another contractor, the Contractor shall inspect and promptly report to the Engineer any defect in such work that renders it unsuitable for such proper execution and results. The Contractor's failure to so inspect and report shall constitute an acceptance of the other contractor's work as fit and proper for the reception of his work, except as to defects which may develop in the other contractor's work after the execution of his work.

#### **5.3.8 Setting out of Works:**

The Contractor shall be responsible for the true, correct and proper setting out of the works in relation to the original points, lines and levels of reference given by the Engineer in writing, subject to above mentioned, all the positions, levels, dimensions and alignment of all parts of the work and for the provision of all necessary instruments, appliances and labour in connection therewith. If at any time during the progress of the work, any error appears or arises in any part of the work, the Contractor on being required to do so by the Engineer shall at once rectify such errors to the satisfaction of the Engineer. The checking of any setting out of line or level by the Engineer or his representatives shall not in any way relieve the Contractor of his responsibility for the correctness thereof and the Contractor shall carefully protect and preserve all benchmarks, site levels, pegs, etc. used in setting out all the work. In case the Contractor is required to revise the setting out of work due to any reason he shall do so without any extra charges.

**5.3.9 Contractor to keep Site clear:** During the execution of work, the Contractor shall keep Site reasonably free from obstructions and shall store or dispose off any constructional plant and surplus material and clear away and remove from site any rubbish or temporary work no longer required.

#### **5.3.10 Clearance of Site on Completion:**

On the completion of the work, the Contractor shall clear away and remove from site all constructional plant surplus materials, rubbish and temporary work of every kind and restore the ground to original level unless otherwise instructed by the Engineer. Contractor shall leave whole of the site, work of every kind, and 10 metres distance from the site periphery clear in workman like conditions to the satisfaction of the Engineer.

#### **5.3.11 Watchman:**

The Contractor shall make his own security arrangements to always guard the site and premises at his own expense. Security arrangements shall be adequate to maintain strict control on the movement of materials and labour. The Contractor shall extend the security arrangements to guard the material stacked and/or fixed on the premises by the sub-Contractors. Nothing extra shall be payable in this regard.

#### **5.3.12 Safety Provisions:**

The Contractor shall at his own expense, arrange for the safety provisions as required under various statutory laws imposed in respect of labour directly or indirectly employed for the performance of the work and shall provide all facilities in connection therewith. Precautions in the safety clause are the minimum necessary and shall not relieve the Contractor from taking additional safety precautions as may be required for particular type of work. Also, mere observance of these precautions shall not absolve the Contractor of his liabilities in case of loss or damage to the property or injury or death of any person including Contractor's labour, Engineer's representatives or any member of the public.

#### **5.3.13 Alterations to be Authorised:**

No alterations in or additions to or omission or abandonment of any part of the works shall be deemed authorised, except under instructions from the Architect/Engineer and the Contractor shall be responsible to obtain in writing such instruction in each and every case from the Principal, Mayoor School,

**5.3.14 Extra Works:**

Should works over and above those included in the Contract be required to be executed at the site, the Contractor shall have no right to be entrusted with the execution of such works which may be carried out by another Contractor or Contractors or by other means at the option of EMPLOYER.

**5.3.15 Adherence to Specifications and Drawings:**

The whole of the works shall be executed in perfect conformity with the Specifications and Drawings. If the Contractor performs any work in a manner contrary to the Specifications or Drawings or any of them and without such reference to the Engineer, he shall bear all the costs arising or ensuing therefrom and shall be responsible for all losses to EMPLOYER.

**5.3.16 Drawings and Specifications of the Works:**

The Contractor shall keep one copy of Drawings and Specifications at the site in good order, and also such other Contract Documents as may be necessary, to be made available to the Engineer and the Engineer's representatives.

**5.3.17 Ownership of Drawings and Specifications:**

All drawings and specifications and copies thereof furnished by Architect/Employer to the Contractor are deemed to be the property of Architect. They shall not be used on other works and with exception of the signed Contract set, shall be returned by the Contractor to the Architect on completion of the works or Termination of the Contract.

**3.18 Compliance with Contractor's request for details:**

The Architect/Engineer shall furnish with reasonable promptness after receipt, by him of the Contractor's request for the same, additional instructions by means of Drawings or otherwise, necessary for the proper execution of the works or any part thereof, all such Drawings and instructions shall be consistent with the Contract Documents and reasonably inferable therefrom.

**5.3.19 Meaning and intent of Specifications & Drawings:**

If any ambiguity arises as to the meaning and intent of any portion of the Specifications and Drawings or as to execution or quality of any work or material or as to the measurements of the works, the decision of the Engineer thereon shall be final subject to appeal (within seven days of such decision being intimated to the Contractor) to the Architect who shall have the power to correct any errors, omissions, or discrepancies in the Specifications, Drawings, classification of work or materials, and whose decision in the matter, in dispute or doubt, shall be final and conclusive.

**5.3.20 Work during Night:**

The Contractor shall not carry out any work between sunset and sunrise without the previous permission of the Engineer.

**5.3.21 Damage to EMPLOYER property and private life and property:**

The Contractor shall be responsible for all risks to the works and for trespass and shall make good at his own expense all loss or damage whether to the works themselves or to any other property of EMPLOYER or the lives, persons or property of others from whatsoever cause in connection with the works until they are taken over by EMPLOYER even though all reasonable and proper precautions may have been taken by the Contractor and in case EMPLOYER shall be called upon to make good any such costs, loss or damages, or to pay compensation (including that payable under the provisions of the Workmen's Compensation Act or any Statutory Amendment thereof) to any person or persons sustaining damage as aforesaid by reason or any act, or any negligence or omission on the part of the Contractor, the amounts of any costs or charges (including costs and charges in connection with legal proceedings), which EMPLOYER may incur in reference thereto, shall be charged to the Contractor. EMPLOYER shall have the power and right to pay or to defend or compromise any claims of threatened legal proceedings or in anticipation of legal proceedings being instituted consequent on the action or default of the Contractor, to take such steps as may be considered necessary or desirable to ward off or mitigate the effect of such proceedings, charging to the Contractor, as aforesaid, any sum or sums of money which may be paid and any expenses whether for reinstatement or otherwise which may be incurred and the propriety of any such payment, defence or compromise, the incurring of any such expenses shall not be called in question by the Contractor.

**5.3.22 Sheds, Store-houses and Yards:** The Contractor shall at his own expense provide himself with sheds, store-houses and yards in such situations and in such numbers as in the opinion of the Engineer are requisite for carrying on the works and the Contractor shall keep at each of such sheds store-houses and yards a sufficient quantity of materials and plant in stock as not to delay the carrying out of the works with due expedition and the Engineer and the Engineer's representatives shall have free

access to the said sheds, store houses and yards at any time for the purposes of inspecting the stock of material and plant so kept in hand, and any materials or plant which the Engineer may object to shall not be brought upon or used in the works, but shall be forthwith removed from the sheds, store-houses or yards by the Contractor. The Contractor shall at his own expense provide and maintain suitable generators, soaking vats, etc. or any other equipment necessary for the proper execution of the works.

#### 5.3.23 Deleted

5.3.25 The materials brought to site by the Contractor and before they are allowed to be used in the works by the Engineer shall be inspected by the Contractor to ensure that these conform to the required stipulations and record a certificate to that effect in the register to be maintained for this purpose.

#### 5.3.26 Workmanship:

The Contractor shall engage specialist firms for the execution of the following works:

- (i) Electrical sub-Contractor(s) (holding registration with Government Departments).
- (ii) Plumbing, sanitary, sewerage and water supply sub-Contractor(s) (holding registration with Government Departments).
- (iii) Water proofing works (company's authorised applicator)
- (iv) Anti-termite works (company's authorised applicator)

#### 5.3.27 Removal of Improper Work and Materials:

The Engineer or the Engineer's Representative shall be entitled to order from time to time:

- (i) The removal from the site (within the time specified) any materials which in his opinion are not in accordance with the Specifications or Drawings.
- (ii) The substitution of proper and suitable materials.
- (iii) The removal and proper re-execution (not withstanding any previous tests thereof or "On Account" payments thereof) of any work which in respect of materials or workmanship is not in his opinion in accordance with the specifications and in case of default on the part of the Contractor in carrying out such order, EMPLOYER shall be entitled to levy a penalty of **Rs.10,000/- per month** and continuous noncompliance of order will entitle EMPLOYER to rescind the Contract, under relevant clause of these conditions.

#### 5.3.28 Facilities for Inspection and Access to Site of work:

The Contractor shall afford the Principal, Mayoer School, authorities, Engineer, Architect and their representatives every facility for entering in and upon every portion of the work at all hours for the purpose and the Engineer and the Engineer's representative shall at all times have free access to every part of the works and to all places/workshops/factories at which material for the works are stored or being obtained/manufactured.

#### 5.3.29 Examination of work before covering up:

The Contractor shall give seven days' notice to the Engineer or Engineer's representative whenever any work or materials are intended to be covered up by the earth, in bodies or walls or otherwise to be placed beyond the reach of measurement in order that the work may be inspected or that correct dimensions may be taken before being so covered, placed beyond the reach of measurement in default whereof the same shall at the option of the Engineer or the Engineer's representative be uncovered and measured at the Contractor's expense or no payment shall be made for such work or materials.

#### 5.3.30 Panel Room Provided by Employer:

The Employer shall provide a covered secure panel room of the required size to install string inverters in the vicinity of the photo voltaic panels on the terrace. All cables from the PV modules shall be taken to this panel room in cable trays of approved specification.

#### 5.3.31 Arrangements for Water and Electricity:

The Owner shall provide power for construction at one point at site of work at actual cost. The contractor shall provide all temporary service lines, boards, switches, cut-outs etc. as required for his used on the works and remove the same on completion at his own cost. If the State Electricity Board supply is not available, then the contractor will have to make his own arrangement to carry out the work uninterrupted. The contractor shall be charged at relevant commercial rates of the state electricity board for the actual units of electricity consumed at the site. The contractor shall also pay 0.75% of the civil work as water charges for water provided by the Employer.

#### 5.3.32 Property in Materials and Plant:

The materials and plant brought by the Contractor upon the site or on the land occupied by the Contractor in connection with the works and intended to be used for the execution thereof shall



immediately as they are brought upon the site or the said land, be deemed to be the property of EMPLOYER. Such of them as during the progress of the works are rejected by the Engineer or are declared by him not to be needed for the execution of the work or such as on the grant of the certificate of completion remain unused shall immediately on such rejection, declaration or grant cease to be deemed property of EMPLOYER and the Contractor may then (but not before) remove them from the site or the said land. This clause shall not in any way diminish the liability of the Contractor nor shall EMPLOYER be in any way responsible for any loss or damage which may happen to or in respect of any such materials or plant either by the same being lost, stolen, or destroyed by fire, tempest or otherwise.

**5.3.33 Tools, Plant and Materials supplied by EMPLOYER:**

The Contractor shall take all reasonable care of all tools, plant and materials or other property, whether of alike description or not, belonging to EMPLOYER and committed to his charge for the purpose of the works and shall be responsible for all damage or loss caused by him, his agents, permitted sub- Contractors or his workmen or others while they are in his charge. The Contractor shall sign all receipts for tools, plants and materials made over to him by Engineer and on completion of the works shall hand over, the unused balance of the same to the Engineer in good order and repair, (fair wear and tear excepted) and shall be responsible for any failure to account for the same or any damage done thereto.

**5.3.34 Precautions during progress of Works:**

During the execution of works, unless otherwise specified, the Contractor shall at his own cost provide materials for and execute all shoring, timbering, shuttering and scaffolding, fencing and structuring work etc. as are necessary for the stability and safety of all structures, excavations and works and shall ensure that no damage, injury or loss is caused or likely to be caused to any person or property.

**5.3.35 Deleted**

**5.3.36 Rates for Items of Works:**

The rates entered in the accepted Schedule of Rates of the Contract are intended to provide for works duly and properly completed in accordance with the General and Special (if any) Conditions of Contract and the Specifications and Drawings together with such enlargements, extensions, diminution, reductions, alterations, or additions as may be ordered without prejudice to the generality thereof and shall be deemed to include and cover superintendence and labour, supply, including full freight of material, stores, patterns, profiles, moulds, fittings, centering, scaffolding, shoring, props, timber, machinery, derricks, tackle, ropes, pegs, posts, tools, etc. and all apparatus and plant required on the works, except such materials as may be specified in the contract to be supplied to the Contractor by EMPLOYER, the erections, maintenance and removal of all temporary works, all watching, lighting, bailing, pumping and draining, all prevention of or compensation for trespass, all barriers and arrangements for the safety of the public or of employees during the execution of works all sanitary and medical arrangements for labour camps as may be prescribed by EMPLOYER, the setting of all work and of the construction, repair and upkeep of all center lines, bench marks and level pegs thereon, site clearance, all fees, duties, royalties, rent and compensation to owners for surface damage or taxes and impositions payable to local authorities in respect of land, structures and all materials supplied for the works, or other duties or expenses for which the Contractor may become liable or may be put to under any provision of law for the purpose of or in connection with the execution of the contract, and all such other incidental charges or contingencies as may have been specially provided for in the Specifications.

**5.3.37 Co-ordination of Work:**

At the commencement of work and from time to time, the Contractor shall confer with other Contractors, sub-Contractors, persons engaged on separate contracts in connection with the works, and with the Engineer for the purpose of the co-ordination and execution of various phases of works. The Contractor shall ascertain from the other Contractors. in connection with the works, the extent of all chiseling, cutting and forming of all openings, holes, grooves etc. as may be required to accommodate the various services. The Contractor shall ascertain the routes of all services and the positions of all floor and wall outlets, traps, etc. in connection with the installation of plants, services and arrange for the construction of work accordingly. The breaking and cutting of complete work shall not be done unless specifically authorised in writing by the Engineer. All breaking shall be done by the Contractor for execution of work and no work shall be done over broken or patched work without first ascertaining that the broken surface is adequately prepared and reinforced to receive and hold the future work. The work, broken without authorisation, will be subject to replacement at the direction of the Engineer.

**5.3.38 Access Roads:**

The Contractor shall provide necessary access roads to the site of work from the nearest thoroughfare/right of way at his cost.

#### **5.3.39 Suspension of Works:**

The Contractor shall on the order of the Engineer suspend the progress of the works or any part thereof or such time or times and in such manner as the Engineer may consider necessary and shall during such suspension properly protect and secure the work so far as is necessary in the opinion of the Engineer. No compensation shall be payable to the Contractor on whatsoever account for the suspension of work. In the event such suspension exceeds 14 days, the Contractor shall be entitled to such extension of time for completion of the works as the Engineer may consider proper and reasonable with regard to period or periods of such suspension provided suspension has not been ordered on account of any default on the part of the Contractor.

### **GUARANTEES**

#### **5.3.40 Quality of Work:**

The Contractor shall guarantee that the materials and workmanship are the best of their respective kinds for the service intended and that all items of work will be free from all inherent defects in workmanship and material. he shall also guarantee that the work will not fail in any respect due to quality of material, workmanship and methods of construction. The specifications assume a proper degree of skill on the part of the Contractor and workmen employed. The Contractor shall consult the Engineer, whenever in his judgment variation in the methods of construction or in the quality of materials would be beneficial or necessary to fulfill the guarantees called for. Such variations may be made by the Contractor only when authorised by the Engineer.

#### **5.3.41 Rejection:**

If during the period of maintenance any work or material fails in any respect to meet the above guarantee, the Contractor shall replace such work or material in a condition which will meet the above guarantee, immediately.

#### **5.3.42 Cost of Execution of work or repair etc.:**

All work or repair shall be carried out by the Contractor at his own expenses if the necessity thereof shall in the opinion of the Engineer be due to the use of materials or workmanship not in accordance with the contract or on account of neglect or failure on the part of the Contractor to comply with any obligation expressed or implied on the Contractor's part under the Contract. If in the opinion of the Engineer such necessity shall be due to any other cause, the value of such work shall be ascertained and paid for as if it were additional work.

#### **5.3.43 Remedy on Contractor's failure to carry out works required:**

If the Contractor fails to do any such work or repair within the stipulated time as aforesaid required by the Engineer, the Engineer shall be entitled to carry out such works or repair at the Contractor's cost. The Engineer shall be entitled to recover from the Contractor the cost thereof or may deduct the same from any money due or that may become due to the Contractor.

## **IV. VARIATIONS IN EXTENT OF CONTRACT**

#### **5.4.0 Powers of Modifications to Contracts:**

The quantities of the various items indicated in the "Schedule of Quantities" forming part of this Contract are approximate and are subject to variations based on the ground strata, final detailed drawings and instructions issued during the execution of work and other conditions under which the works are executed. The Employer reserves the right to make variations in the quantities or delete any of the item(s) altogether from the Schedule of Quantities and/or order extra items to be executed or substitute the item in the Schedule of Quantities, such variations shall in no way affect this Contract. The rates quoted by the Contractor and accepted as per these Contract Documents shall be firm and the Contractor shall not be entitled to any revision in rates due to any variation in quantities of items shown in the Schedule of Quantities. Time for completion of the work shall be modified in the proportion that of the actual work verses the original Contract work and the certificates of the Engineer shall be conclusive to such proportion.

#### **5.4.1 Schedule of Quantities:**

The Schedule of Quantities, unless otherwise stated, shall be deemed to have been prepared in accordance with the standard method of measurement Roof Top Solar PV (Photo Voltaic) Power Plant. Any error in description or in quantity or omission of items from the Schedule of Quantities shall not vitiate this Contract but shall be rectified and the value thereof as ascertained hereof shall be added to or deducted from the Contractor's amount (as the case may be) provided that there shall be no rectification of errors in the Contractor's schedule of rates.

#### **5.4.2 Rate for Extra, Additional or Altered or Substituted work:-**

The Employer shall have full powers to order the execution of extra additional, altered or substituted items not included in the Schedule of Quantities forming part of this Contract. The execution of such items and/or any instructions issued thereafter shall not, in any way, affect or vitiate the Contract and the Contractor shall be bound to carry out all such items required under the same terms and conditions as per these Contract Documents.

- (i) If the rate for additional, altered and substituted work directly available in the Contract for the work, the Contractor is bound to carry out the work at the same rates as are available in the Contract for the work.
- (ii) If the rates for additional, altered or substituted work are not directly available in the Contract for the work, the rates will be derived from the rates for a similar class of work as are specified in the Contract for the work.
- (iii) If the rates for altered, additional or substituted work cannot be determined in the manner specified in sub-clause (i) and (ii) above, the rates for such items will be worked out on the basis of rates given in BSR 2013 Ajmer. **The rates for additional, altered and substituted work shall be paid as per BSR 2019 Jaipur @..... % above/below.**
- (iv) If the rates for the altered, additional or substituted work cannot be determined in the manner specified in sub-clause (i) to (iii) above, then the Contractor shall execute the work under instructions of the Architect/ Engineer and he will be paid on the basis of market analysis submitted by the Contractor and approved by the Architect/Engineer. For the purpose of market analysis of rates, overheads and Contractors' profit shall be taken at 15%. However, if the Contractor is not satisfied with the decision of the Architect/Engineer in respect of the rates so approved by him, then he may appeal to the Principal, Mayoora School, within 30 days of getting the decision of the Engineer supported by analysis of the rates or rates claimed. The Principal's decision after hearing both the parties in the matter would be final and binding on the Contractor and Engineer/ Architect.

## V. MEASUREMENTS, CERTIFICATES AND PAYMENTS

### 5.5.0 Quantities in Schedule of Rates annexed to Contract:

The quantities set out in the accepted Schedule of Rates with items of work quantified are the estimated quantities of the work and they shall not be taken as the actual and final quantities of the works to be executed by the Contractor in fulfillment of his obligations under the contract.

### 5.5.1 Measurements of Works:

- (i) The Contractor shall be paid for the works at the rates of the accepted Schedule of Rates and for all the authorised extra works at rates determined on the measurements taken by the Contractor and verified by the Engineer or the Engineer's Representative in accordance with the rules prescribed for the purpose by EMPLOYER.
- (ii) The quantities for items, the unit of which in the accepted Schedule of Rates is 100 or 1000 shall be calculated to the nearest whole number. Any fraction below half being dropped and half and above being taken as one, for items the unit of which in the accepted Schedule of Rates is single, the quantities shall be calculated to two places of decimals.
- (iii) Such measurements will be taken of the work in progress from time to time and at such intervals as in the opinion of the Engineer shall be proper having regard to the progress of the works. The date and time on which 'on account' or final measurement are to be verified shall be communicated to the Contractor who shall be present at the site and shall sign the results of the measurements.

### 5.5.2 On Account Payments:

- (i) The Contractor shall be entitled to be paid from time to time by way of "On-account payable" only for such works as in the opinion of the Engineer he has executed at site subject to any deduction which may be made from the same.
- (ii) Detailed measurements for the work done at site will be recorded in the prescribed measurement book by the Contractor and On-Account Bill shall be prepared and submitted to the Engineer who will pass the same for payment after verification.
- (iii) The measurements submitted by the Contractor shall be jointly verified on the date and time fixed by the Engineer and the Contractor shall be present at site and shall sign the results of the measurements which will also be signed by the Engineer/Engineer's representative. These measurements so verified in the prescribed measurement book will be treated as an acknowledgment and acceptance of the accuracy of the measurement. Failing the Contractor's attendance, the work will be checked and measured up in his absence and such measurements, shall notwithstanding such absence, be binding on the Contractor whether or not he shall have signed the measurement book, provided always that any objection made by the Contractor in writing to any measurement shall be duly investigated and considered in the manner set-out above.
- (iv) The On-Account Bill shall be submitted in the prescribed proforma approved by the Engineer. No bill submitted incomplete or not in the prescribed manner will be entertained. Once the On-Account Bill is submitted by the Contractor complete in all respects to the satisfaction of the Engineer, the same will normally be paid within 15 days of submission. The Contractor shall, however, not be entitled for any interest or any other compensation due to delayed payment. "The bill on receipt in corporate office of EMPLOYER after its having been checked at site will be passed for payment to the extent of **75%** of net amount which will be treated as advance. This amount will be adjusted while passing running/ on-account bill and balance **25%** paid thereafter. The next running/on account bill will be prepared only after the first bill is cleared."
- (v) Normally On-Account payments for the work done by the Contractor shall be made once a month provided that the gross value of work done since the previous payment is not less than **Rs.20 lacs**.

### 5.5.3. Final Measurement & Payment:

- (i) When the works have been actually completed and the Engineer shall have certified in writing that they have been so completed and the Engineer has reasonably satisfied himself about the same, the Contractor shall submit his final bills of quantities supported by detailed measurements within **7 days**. Subject to the joint checking of the measurements by the Engineer and the Contractor, the Engineer shall arrange to effect actual payment of such of the amounts as are undisputed and accepted after checking therefrom of the amounts due to the Contractor in terms of the Contract.
- (ii) The Contractor shall be entitled to the payment of the final bill on the basis of final certificate to be issued in writing by the Engineer at the expiration of the period referred to as the "Defects Liability Period" in the Appendix hereto from the date of virtual completion or as soon as after the expiration of such period as the works shall have been finally completed and all defects made

good according to the true intent and meaning hereof whichever shall last happen, provided always that the issue by the Engineer of any certificate during the progress of the work and after the completion shall not relieve the Contractor from his liability in cases of fraud, dishonesty, or fraudulent concealment relating to the works or materials or to any matter dealt within the certificate in case of all defects and insufficiencies in the works or materials which on reasonable examination could not have been disclosed. No certificate of the Engineer shall of itself be conclusive evidence that any work or material which it relates are in accordance with the Contract and the Engineer therefore be empowered to withhold such sum or sums as deemed necessary for the time being till final measurements have been made and quantities and quality of work done have been checked and determined.

- (iii) The Engineer shall have power to withhold any certificate/payment if the works or any part thereof is not carried out to his satisfaction or some discrepancies or accounts/audit objections are noticed and raised requiring clarification or rectification(s).
- (iv) In case of termination/rescinding of the Contract, Contractor shall be required to measure work within seven days from the date of termination/rescinding for joint verification by the Engineer, failing which the Engineer will record the measurements after giving due notice to the Contractor of the date and time of the measurement to be recorded and in case the Contractor still fails to witness the measurements, then the measurements so recorded by the Engineer will be the final and binding on the Contractor.

#### **5.5.4 Delayed Payments:**

All payments as due to the Contractor in pursuance of any certificate given by the Engineer shall be made promptly unless some bill has been held up under objection in writing, pending clarification or reply from the Contractor. All objections shall be resolved to the satisfaction of the Employer if necessary by holding meetings and discussions, minutes whereof shall be recorded. No interest, however, shall be claimed and payable for such delayed payments.

**5.5.5.1 Maintenance of Works:** The Contractor shall at all times during the progress and continuance of the works and also for the period of maintenance (Defects Liability Period) specified in the Tender form and after the date of issue of the certificate of completion by the Engineer or any other earlier date subsequent to the completion of the works that may be fixed by the Engineer be responsible for and effectually maintain and uphold in good substantial, sound and perfect condition all and every part of the works and shall make good from time to time at all times as often as the Engineer shall require, any damage or defect that may during the above period arise in or be discovered or be in any way connected with the works, provided that such damage or defect is not directly caused by act of providence or insurrection or civil riot and the Contractor shall be liable for and shall pay and make good to the Employer whenever required by the Engineer to do so, all losses, damages, costs and expenses they or any of them may incur or be put to or be liable to by reason or in consequence of the operations of the Contractor or of his failure in any respect.

#### **5.5.5.2 Urgent measures/Emergency works:**

Any Urgent measures/Emergency works which in the opinion of the Employer, become necessary during the progress of the work to obviate any risk of accident or failure, or which becomes necessary for security or rectification of essential services, during the defects liability period, shall be carried out by the Contractor without any extra charges. If any emergency work(s) become necessary and Contractor delays or fails to carry out such work(s), the Employer shall get the same work(s) carried out by any other agency at the risk and cost of the Contractor. All such expenses shall be recovered from the Contractor.

#### **5.5.5.3 Handing over services and site Development Works:**

The Contractor shall hand over the site development works, i.e. sewerage, drainage, water supply etc. to the concerned authorities in good substantial, sound and perfect condition, as acceptable to the concerned authorities at his own cost, including liaison with and arranging inspection by, concerned local authorities.

#### **5.5.6 Period of Maintenance for Complete Work: (Defects Liability Period)**

The period of maintenance for the works shall be **Twelve months** starting from the date of virtual completion of the work or as certified by the Engineer.

#### **5.5.7 Contract valid during Maintenance Period:**

The Contract shall remain valid and in force until the expiry of maintenance (Defect Liability Period) period.

#### 5.5.8 Certificate of Completion of Works:

As soon as the work is completed, the Contractor shall give notice of such completion whether the whole of the work or any part of the work for which a separate date of completion is stipulated in the Contract to the Engineer. Within thirty days of receipt of such notice Engineer shall inspect the work and shall also arrange for carrying out of such tests that may be prescribed under the Contract. If the Engineer notices any incomplete items of works or any defects which are to be rectified by the Contractor or if any part of or whole of the works fails to pass the specified tests, the Engineer shall furnish to the Contractor list of all such incomplete works, deficiencies, defects failure to pass test etc. and may refuse to issue a Certificate of Completion to the Contractor, provided, however, that such certificate shall not be refused only on the grounds of any defects in the work required to be carried out in respect of Contracts/items wherein a specific Defect Liability Period is provided for. If in the opinion of the Engineer, the works have been satisfactorily completed and have satisfactorily passed its final test or test that may be prescribed, the Engineer shall issue a Certificate of Completion duly accepted by the Employer indicating:

- (i) the date of completion
- (ii) Items for which payment shall be made at reduced rates and
- (iii) Defect Liability Period, if any, shall commence from the date of issue of such certificate, in case separate periods of completion have been specified for items or groups, the Engineer shall issue separate Completion Certificates for such items or groups of items. No completion certificate shall be issued nor shall the work be considered to be complete till the Contractor have removed from the premises on which the work has been executed all scaffolding, sheds and surplus materials except such as are required for rectification of defects, rubbish and all huts and sanitary arrangements, required for his workmen at the site in connection with the execution of the work as shall have been erected by the Contractor or the workmen and cleaned all dirt from the parts of building(s) in, upon or about which the work has been executed or of which he may have had possession for the purpose of the execution thereof and cleaned floors, gutters and drains, eased doors and sashes, oiled locks and fastening labeled keys clearly, handed them over to the Engineer or his representatives and made the whole premises fit for immediate occupation for use to the satisfaction of the Engineer. If the Contractor shall fail to comply with any of the requirements of these conditions, as aforesaid, on or before the date of completion of the works, the Engineer may at the expense of the Contractor fulfil such requirements and dispose of the scaffolding, surplus materials and rubbish etc. as he thinks fit and the Contractor shall have no claim in respect of any scaffolding or surplus materials except for any sum actually realised by the sale thereof less the cost of fulfilling the requirements and any other amount that may be due from the Contractor. If the expenses of fulfilling such requirements is more than the amount realised on such disposal as aforesaid, the Contractor shall forthwith on demand pay such excess. If at any time before completion of the entire work, items or groups of items for which separate periods of completion have been specified are completed, the Engineer shall take possession of any part or parts of the same (any such part(s) being hereinafter in the condition referred to as the relevant part) then notwithstanding anything expressed or implied elsewhere in this Contract.
- (iv) Within thirty days of the date of completion of such items or groups of items or of possession of the relevant part, the Engineer shall issue Completion Certificate for the relevant part as per condition above provided the Contractor fulfills his obligations under that condition for the relevant part.
- (v) The Defects Liability Period in respect of such items and the relevant part shall be deemed to have commenced from the certified date of completion of such items or the relevant part as the case may be.
- (vi) The Contractor may reduce the value insured by the full value of the completed items or relevant part as estimated by the Engineer for this purpose. This estimate shall be applicable for this purpose only and for no other purpose.

#### 5.5.9 Contractor not absolved by Completion Certificate:

The Certificate of Completion in respect of the works referred to in **Clause 5.5.6** shall not absolve the Contractor from his liability to make good any defects, imperfections, shrinkage or faults which may appear during the period of maintenance specified in the tender arising in the opinion of the Engineer from materials or workmanship not in accordance with the Drawings or Specifications or instructions of the Engineer which defects, imperfections, shrinkage or faults shall upon the directions in writing of the Engineer be amended and made good by the Contractor at his own cost; and in case of default on the part of the Contractor; the Engineer may employ labour and material or appoint another Contractor to amend and make good such defects, imperfections, shrinkage's and faults and all expenses consequent thereon and incidental thereto shall be borne by the Contractor and shall be recoverable from any money due to him under the Contract. Any defect, shrinkage, settlement or other faults which may appear within the "Defects Liability Period" stated in **Clause 5.5.6** above or, if one stated, then within twelve months after the virtual completion of the works arising in the opinion of the Engineer from materials or

workmanship not in accordance with the Contract, and shall upon the directions in writing of the Engineer, and within such reasonable time as shall be specified therein, be amended and made good by the Contractor, at his own cost and unless the Employer in consultation with their Engineer shall decide that he ought to be paid for such amending and making good, and in case of default the Employer may employ and pay other persons to amend and make good such damage, loss and all expenses shall be recoverable from him by the Employer upon the Engineer's Certificate in writing from any money due or that may become due to the Contractor, or the Employer may in lieu of such amending and making good by the Contractor deduct from any moneys due to the Contractor a sum to be determined by the Engineer equivalent to the cost of amending such work and in the event of the amount retained being insufficient, recover the balance from the Contractor together with any expenses the Employer may have incurred in connection therewith. Should any defective work have been done or material supplied by any sub-Contractor employed on the works, the Contractor shall be liable to make good in the same manner as if such work or material had been done or supplied by the Contractor. The Contractor shall remain liable under the provisions of this clause notwithstanding the signing by the Engineer of any certificate or the passing of any accounts.

**5.5.10 Approval only by Maintenance Certificate:**

No certificate other than the maintenance certificate referred to in **Clause 5.5.11** of these conditions shall be deemed to constitute approval of any work or other matter in respect of which it is issued or shall be taken part thereof or of the accuracy of any claim or demand made by the Contractor or additional or varied work having been ordered by the Engineer nor shall any other certificate conclude or prejudice any of the powers of the Engineer .

**5.5.11 Maintenance Certificate:**

The contract shall not be considered as complete until a maintenance certificate is signed by the Engineer stating that the works have been completed and maintained to his satisfaction. The maintenance certificate shall be given by the Engineer upon the expiration of the period of maintenance as soon as thereafter as any works ordered during such period shall have been completed to the satisfaction of the Engineer and full effect shall be given to this clause notwithstanding the taking possession of or using the works or any part thereof by EMPLOYER.

**5.5.12 Cessation of Employer's Liability:**

EMPLOYER shall not be liable to the Contractor for any matter arising out of or in-connection with the Contract or the execution of the works unless the Contractor shall have made a claim in writing in respect thereof before the issue of the maintenance certificate under this clause.

**5.5.13 Unfulfilled Obligations:**

Notwithstanding the issue of the maintenance certificate to the Contractor, the Contractor shall remain liable for the fulfillment of any obligation incurred under the provisions of the Contract prior to the issue of the maintenance certificate by Architect which remains unperformed at the time such certificate is issued and for the purposes of determining the nature and extent of any such obligation, the Contract shall be deemed to remain in force between the parties hereto.

**5.5.14 Records to be produced by the Contractor for inspections:**

The Contractor shall whenever required by the Engineer or his authorised representatives, produce or cause to be produced for examination any quotation, invoice cost or other accounts, books, vouchers, receipts, letters, memorandum or any copy of or extract from any such documents and also furnish information as may be required relating to the execution of this contract or relevant for verifying or ascertaining the cost of execution of this contract, or ascertaining that materials supplied by the Contractor are in accordance with the Specifications laid down in the contract. The Employer's decision on the question of relevancy of any documents or information or returns will be final and binding on the Contractor. If any part of the item of the work is allowed to be carried out by a sub-Contractor or any subsidiary or allied firm, the Engineer shall have power to scrutinise the books of such sub- Contractor or any subsidiary or allied firm through the Contractor and shall have powers to examine and inspect the same. The obligations imposed above are without prejudice to the obligations of the Contractor under any statute, rules or orders binding on the Contractor.

**5.5.15 Withholding and Lien in respect of sums claimed:**

Whenever any claim or claims for payment of a sum of money arises out of or under the Contract against the Contractor, the Employer shall be entitled to withhold and also have a lien to retain such sum or sums in whole or in part from the security, if any, deposited by the Contractor, and for the purpose aforesaid, the Employer shall be entitled to withhold the said cash Security Deposit or the security in any other form including Bank Guarantee(s) and also have a lien over the same pending finalisation or adjudication of any such claims. In the event of the security being insufficient to cover the claim amount

or amounts or if no Security has been taken from the Contractor, the Employer shall have the right to withhold and have a lien to retain to the extent such claim amounts from any sum or sums, found payable or which any time with any other office, subsidiary of the Employer thereafter may become payable to the Contractor either alone or jointly with others under the same Contract or any other Contract with the Employer or pending finalisation or adjudication of any such claims. It is an agreed term of the Contract that the sum of money or moneys so withheld or retained under a lien referred to above by the Employer shall be kept withheld or retained by the Employer till the Employer's claim arising out of or under the Contract are mutually settled or determined by the Arbitrator (if the Contract is governed by the arbitration clause) or by the competent court, as the case may be, and that the Contractor will have no claim for interest or damages, whatsoever, on any account in respect of such withholding or retention under the lien referred to above and duly notified as such to the Contractor. For the purpose of this clause, where the Contractor is a partnership firm or a limited company, the Employer shall be entitled to withhold and also have a lien to retain towards such claimed amount or amounts in whole or in part from any sum found payable to any partner/limited company, as the case may be, whether in his individual capacity or otherwise.

#### **5.5.16 Lien in respect of claim in Other Contract:**

Any sum of money due and payable to the Contractor either alone or jointly with others including the Security Deposit returnable to him, under the Contract, may be withheld or retained by way of a lien by the Employer against any claim of Employer or in respect of payment of a sum of money arising out of or under any other Contract made by the Contractor with the Employer or any other office or subsidiary of the Employer. It is an agreed term of the Contract that the sum of money so withheld or retained under this clause by the Employer shall be kept withheld or retained by the Employer till the claim arising out or any other Contract is either mutually settled or determined by the Arbitrator (if the Contract is governed by the arbitration clause) or by the competent court, as the case may be and the Contractor shall have no claim for interest or damages, whatsoever, on any account or on any other account in respect of any sum of money withheld or retained under this clause and duly notified to the Contractor.

#### **5.5.17 Signature on Receipt for Amounts:**

Every receipt of money which may become payable or for any security which may become transferable to the Contractor under this Contract shall if signed in the partnership name by any of the partners of a Contractor, firm or by a person (holding power of attorney if the Contractor's firm is a limited company) be a good and sufficient discharge to the Employer in respect of money or security purported to be acknowledged thereby. In the event of the death of any of the partners during the currency of the Contract, it is hereby expressly agreed that every receipt by any one of the surviving partner shall, so signed as aforesaid be good and sufficient discharge as aforesaid provided that nothing in this clause shall be deemed to prejudice or effect any claim which the Employer may hereinafter have against the legal representatives of any of Contractor's partners so doing, for or in respect of breach of any of the Conditions of the Contract, provided also that nothing in this clause contained shall be deemed to prejudice or affect the respective rights or obligations of the Contractor's partners and of the legal heirs/representatives of any deceased Contractor/ Contractor's Partner(s).

## **VI. L A B O U R**

#### **5.6.1 Compliance with Labour Laws:**

Contractor shall comply with all laws and statutory regulations dealing with the employment of labour such as:

- (i) The payment of Wages Act, 1936.
- (ii) The Minimum Wages Act, 1938.
- (iii) The Workmen's Compensation Act, 1923.
- (iv) The Contract Labour (Regulations and Abolishing) Act.
- (v) Employer's Liability Act, 1938.
- (vi) Industrial Disputes Act, 1947.
- (vii) Maternity Benefit Act, 1961.
- (viii) Mines Act.
- (ix) The Employees State Insurance Act, 1948, Safety Code, Labour Welfare Acts or Rules or any modifications thereof, any other Laws & Regulations framed by the Competent Legislative Authorities from time to time.
- (x) Employees Provident Fund.

#### **5.6.2 Rest Days and Default Under Labour Laws:**

So far as practicable, the Contractor shall observe days of rest for the labour so as to coincide with the days of rest specified by the Employer for his employees. The Employer on having received report from



the competent Inspecting Officer as defined under any/all of the above Acts, shall have the power to deduct from the money due to the Contractor any sum required or estimated to be required for making good the loss suffered by the worker/workers/ for the non-fulfillment of the Conditions of the Contract for the benefit of the workers, non-payment of wages or wrongful deductions made from the wages. The Contractor shall indemnify Employer against any payments to be made under and for the observance of regulations aforesaid without prejudice to his right to claim indemnity from his sub-Contractors.

## VII. CLAIMS

### 5.7.1 Monthly Statement of Claims:

The Contractors shall prepare and furnish to the Engineer once in every month an account giving full and detailed particulars of all claims for any additional expenses to which the Contractor may consider himself entitled and of all extra or additional works ordered by the Engineer which he has executed during the preceding month and no claim for payment for any such work will be considered which has not been included in such particulars.

### 5.7.2 Signing of 'No Claim' Certificate:

The Contractor shall not be entitled to make any claim, whatsoever, against EMPLOYER under or by virtue of, or arising out of this Contract nor shall EMPLOYER entertain or consider any such claim, if made by the Contractor, after he shall have signed a 'No Claim' certificate in favour of EMPLOYER in such form as shall be required by EMPLOYER after the works are finally measured up. The Contractor shall be debarred from disputing the correctness of the items covered by the 'No Claim' certificate. In such cases, it will be a term of Contract that there is no Arbitration Clause at all.

## VIII. DETERMINATION OF CONTRACT

### 5.8.0 Right of Employer to determine Contract:

The Employer shall be entitled to determine and terminate the Contract at any time should, in the Employer's opinion, the cessation of work become necessary owing to paucity of funds or from any other cause, whatsoever, in which case the value of approved materials at site and of work done to date by the Contractor will be paid for in full at the rate specified in the Contract. Notice in writing from the Employer of such determination and the reason therefor shall be conclusive evidence thereof.

### 5.8.1 Payment on Determination of Contract:

Should the contract be determined under sub-clause 5.8.0 of this Clause, the Contractor shall have no claim to any payment of compensation or otherwise whatsoever on account of any profit or advantage which he might have derived from the execution of the work in full but which he did not derive in consequence of determination of the Contract. The Employer's decision on the necessity and propriety of such expenditure shall be final and conclusive.

### 5.8.2 Determination of Contract owing to Default of Contractor:

If the Contractor should

- (i) become bankrupt or insolvent or
- (ii) make an arrangement with or assignment in favour of his creditors, or agree to carry out the Contract under a committee of Inspection of his creditors, or
- (iii) being a company or corporation, go into liquidation (other than a voluntary liquidation for the purpose of amalgamation or reconstruction) or
- (iv) have an execution levied on his goods or property on the works, or
- (v) assign the Contract or any part thereof otherwise than as provided in Clause 5.2.11 of these conditions, or
- (vi) abandon the Contract or
- (vii) persistently disregard the instructions of the Engineer or contravene any provision of the Contract, or
- (viii) fail to adhere to the agreed programme of work by a margin of 10% of the stipulated period, or
- (ix) fail to remove materials from the site or to pull down and replace work after receiving from the Engineer notice to the effect that the said materials or works have been condemned or rejected or
- (x) fail to take steps to employ competent or additional staff and labour as required, or
- (xi) fail to afford the Engineer or Engineer's representative proper facilities for inspecting the work or any part thereof as required, or
- (xii) promise, offer to give any bribe, commission, gift or advantage either himself or through his partner, agent or servant to any officer or employee of the Employer or to any person of his or on their behalf in relation to the execution of this or any other Contract with the Employer.

5.8.3 Then and in any of the said cases, the Engineer on behalf of the Employer may serve the Contractor with a notice in writing to that effect and if the Contractor does not within seven days after the delivery to him of such notice proceed to make good his default in so far as the same is capable of being made good and carry on the work or comply with such directions as aforesaid to the entire satisfaction of the Engineer, the Employer shall be entitled after giving 48 hours notice in writing under the hand of the Engineer (to rescind the Contract as a whole or in part or parts as may be specified in such notice) and adopt either or both of the following courses:-

- (i) to carry out the whole or part of the work from which the Contractor has been removed by the employment of the required labour and materials, the costs of which shall include lead, lift, freight, supervision and all incidental charges.
- (ii) to measure up the whole or part of the work from which the Contractor has been removed and to get it completed by another Contractor. The manner and method in which such work is completed, shall be at the entire discretion of the Engineer, whose decision shall be final.
- (iii) And in both the cases (a) & (b) mentioned above, Employer shall be entitled
  - (i) to forfeit the whole or such portion of the Security Deposit as it may consider fit; and
  - (ii) to recover from the Contractor the cost of carrying out the work in excess of the sum which would have been payable according to the certificate of the Engineer to the Contractor if the works had been carried out by the Contractor under the terms of the contract, such certificate being final and binding upon the Contractor. Provided, however, that such recovery shall be made only when the cost incurred in excess is more than the Security Deposit proposed to be forfeited and shall be limited to the amount by which the cost incurred in excess exceeds the Security Deposit proposed to be forfeited. The amounts thus to be forfeited or recovered may be deducted from any moneys then due or which at any time thereafter may become due to the Contractor by the Employer under this or any other Contract or otherwise. Provided always that in any case in which any of the powers conferred upon the Employer by - sub-clause 5.8.0 shall have become exercisable and the same not be exercised, the non-exercise, thereof shall not constitute a waiver of any of the conditions thereof and such powers shall notwithstanding the exercisable in the event of any future case of default by the Contractor for which his liability for past and future shall remain unaffected.

**5.8.4 Right of Employer after rescission of Contract owing to default of Contractor:**

In the event of any or several of the courses, referred to in sub-clause 5.8.2 being adopted:

- (i) The Contractor shall have no claim to compensation for any loss sustained by him by reason of his having purchased or procured any materials or entered into any commitments or made any advances on account of or with a view to the execution of the work or the performance of the Contract and Contractor shall not be entitled to recover or be paid any sum for any work thereto or actually performed under the Contract unless and until the Engineer shall have certified the performance of such work and the value payable in respect thereof and the Contractor shall only be entitled to be paid the value so certified.
- (ii) The Engineer or the Engineer's representative shall be entitled to take possession of any materials, tools, implements, machinery and buildings on the works or on the property on which these are being or ought to have been executed, and to retain and employ the same in the further execution of the works or any part thereof until the completion of the works without the Contractor being entitled to any compensation for the use and employment thereof or for wear and tear or destruction thereof.
- (iii) The Engineer shall, as soon as may be practicable after removal of the Contractor fix and determine ex-parte, or by or after reference to the parties or after such investigation or inquiries as he may consider fit to make or institute and shall certify what amount (if any) has at the time of rescission of the Contract been reasonably earned by or would reasonably accrue to the Contractor in respect of the work then actually done by him under the Contract and what was the value of any unused or partially used materials, any constructional plant and any temporary works upon the site.
- (iv) The Employer shall not be liable to pay Contractor any money on account of the Contract until the expiration of the period of maintenance and thereafter until the costs of completion and maintenance damages for delay in completion (if any) and all other expenses incurred by the Employer have been ascertained and the amount thereof certified by the Engineer. The Contractor shall then be entitled to receive only such sum or sums (if any) as the Engineer may certify would have been due to him upon due completion by him after deducting the said amount, but if such amount shall exceed the sum which would have been payable to the Contractor, then the Contractor shall on demand pay to the Employer the amount of such

excess and it shall be deemed a debit due by the Contractor to Employer and shall be recoverable accordingly.

## IX. SETTLEMENT OF DISPUTE

### 5.9.0 Arbitration:

- (i) Any dispute or difference of any nature whatsoever any claim, Gross-claim, or set off the Employer against the Contractor or regarding any right, liability, act, omission or account of any of the parties hereto arising out of or in relation to this agreement shall be referred to the Sole Arbitration of the Principal, Mayoora School, or to an arbitrator who may be nominated by the the Principal, Mayoora School,. The Contractor will not be entitled to raise any objection to any such arbitrator on the ground that the arbitrator is an Officer of the Principal, Mayoora School, or that he has dealt with the matters to which the contract relates or that in the course of his duties as an Officer of the Principal, Mayoora School, he had expressed views on all or any other matters in dispute or difference. In the event of arbitrator to whom the matter is originally referred being transferred or vacating his office for being unable to act for any reason, the Principal, Mayoora School, as aforesaid at the time of such transfer, vacation of office or inability to act may in the discretion of the Principal, Mayoora School, designate another person to act as arbitrator in accordance with the terms of the agreement to the end and intent that the original Arbitrator shall be entitled to continue the arbitration proceeding notwithstanding his transfer or vacation of office as an Officer of Mayoora School, if the Principal, Mayoora School, does not designate another person to act as arbitrator on such transfer, vacation of office or inability of original arbitrator. Such persons shall be entitled to proceed with the reference from the Principal, Mayoora School, or a person nominated by such Principal, Mayoora School, as aforesaid shall act as arbitrator hereunder. The award of the arbitrator so appointed shall be final conclusive and binding on all parties to the agreement subject to the provision of the Arbitration Act. 1940 or any statutory modification or re-enactment thereof and the rules made thereunder for the time being in force shall apply to the arbitration proceeding under this clause.  
(b) The award shall be in writing and published by the arbitrator within, two years after entering upon the reference or within such extended time not exceeding further twelve months as the sole Arbitrator shall be a writing under his own hands appoint. The parties here to shall be deemed to have irrevocably given their consent to the Arbitrator to make and publish the award within the period referred to herein above and shall not be entitled to raise any objection or protest there to under any circumstances whatsoever.
- (ii) The arbitrator shall have power to order and direct either of the parties to abide by, observe and perform all such directions as the arbitrator may think fit having regard to the matters in difference i.e. dispute before him. The arbitrator shall have all summary powers and may take such evidence oral and / or documentary, as the arbitration in his absolute discretion thinks fit and shall be entitled to exercise all powers under the Indian Arbitration Act. 1940, including admission of any affidavit as evidence concerning the matter in difference i.e. dispute before him.
- (iii) The parties against whom the arbitration proceeding have been initiated, that is to say, the Respondents in the proceedings, shall be entitled to prefer a cross-claim, counter-claim or set off before the Arbitrator in respect of any matter in issue arising out of or in relation to the Agreement without seeking a formal reference of arbitration to the Principal, Mayoora School, for such Counter-claim Cross-claim or set off and the Arbitrator shall be entitled to consider and deal with the same as if the matter arising therefore has been referred to him originally and deemed to form part of the reference made by the Director (Personnel).
- (iv) The arbitrator shall be at liberty to appoint, if necessary any accountant or engineer or other technical person to assist him, and to act by the opinion so taken.
- (v) The arbitrator shall have power to make one or more awards whether interim or otherwise in respect of the dispute and difference and in particular will be entitled to make separate awards in respect of claims or cross-claims of the parties.
- (vi) The arbitrator shall be entitled to direct any of the parties to pay the costs of the other party in such manner and to such extent as the arbitrator may in his discretion determine and shall also be entitled to require one or both the parties to deposit funds in such proportion to meet the arbitrators expenses whenever called upon to do so.
- (vii) **Jurisdiction:** The parties hereby agree that the courts in the city of Ajmer alone shall have jurisdiction of entertain any application or other proceedings in respect of anything arising under this agreement and any award or awards made by the sole arbitrator hereunder shall be filed in the concerned courts in the city of Ajmer Only.

**SECTION 6**  
**SPECIAL CONDITIONS OF CONTRACT**

**6.1.0 Insurance for Works:**

The Contractor at the time of signing the Contract or before commencing the execution of the work without limiting his obligations and responsibilities shall insure the works at his own cost and keep them insured until the virtual completion of the contract against all acts of God including Fire, Theft, Riots, War, Floods, etc. with a Nationalised Insurance Agency in the joint names of the Employer and Contractor (the name of the former being placed first in the policy) for the full amount of the contract. Such policy shall cover the property of the Employer and fees for assessing the claim and in connection with his services generally therein and shall not cover any property of the Contractor or of any sub-Contractor or Employee. The Contractor shall deposit the original policy and receipt for the premiums with the Employer within twenty-one (21) days from the date of signing the contract/commencement of execution of work or unless otherwise instructed by the Employer. In default of the Contractor insuring as provided above, the Employer on his behalf may so insure and may deduct the premiums paid from any moneys due or which may become due to the Contractor. The Contractor shall, as soon as any claim under the policy is settled or the work reinstated by the Insurance Office should elect to do so, proceed with all due diligence with the completion of the works in the same manner as though the misfortune/accident had not occurred and in all respects under the same conditions of contract. The Contractor in case of rebuilding or reinstatement after accident, shall be entitled to such extension of time for completion as the Employer deems fit.

**6.1.1 Insurance in respect of damages to persons and property:**

- (i) The Contractor shall be responsible for all injury to persons animals or things and for all structural and decorative damage to property which may arise from the operation or neglect of himself or of any approved sub-Contractor's or Employee's, whether such injury or damage arise from carelessness, accident or any other cause whatsoever in any way connected with the carrying out of this contract. The clause should be held to include any damage to property, building & solar plant, whether immediately adjacent or otherwise, and any damage to roads, streets, footpaths, bridges, sewerage, water supply, other services and works forming the subject of this contract by frost or other inclemency of the weather. The Contractor shall indemnify the Employer and hold him harmless in respect of all and any expenses arising from any such injury or damage to persons or property as aforesaid and also in respect of any claims made in respect of injury or damage under any Acts of Government or otherwise and also in respect of any award of compensation of damages consequent upon such claims.
- (ii) The Contractor shall reinstate all damages of every sort mentioned in this clause, so as to deliver up the whole of the contract works complete and perfect in every respect and so as to make good or otherwise satisfy all claims for damage to the property of third parties.
- (iii) The Contractor shall indemnify the Employer against all claims which may be made against the Employer by any member of the public or other third party in respect of works in consequence thereof and shall at his own expense arrange to effect and maintain, until the virtual completion of the contract, with any Nationalised Insurance Agency in the joint names of the Employer and the Contractor against such risks and deposit such policy or policies with the Employer from time to time during the currency of this contract. The Contractor shall similarly indemnify the Employer against all claims which may be made upon the Employer whether under the Workman's Compensation Act or any other statute in force during the currency of this contract or at common law in respect of any employee of the Contractor or any sub- Contractor and shall at his own expense effect and maintain with an approved office a policy of insurance in the joint names of the Employer and the Contractor (the name of Employer appearing first) against such risks and deposit such policy or policies with the Employer from time to time during the currency of the contract. The Contractor shall be responsible for any thing which may be excluded from the Insurance policies above referred to and also for all other damages to any property arising out of and incidental to the negligent or defective carrying out of this contract. He shall also indemnify the Employer in respect of any costs, charges or expenses arising out of any claim or proceedings and also in respect of any award of or compensation of damages arising therefrom.
- (iv) The Employer shall be at liberty and is empowered to deduct the amount of any damage, compensation costs, charges and expenses arising or accruing from or in respect of any such claim or damage from any sum or sums due to or become due to the Contractor including the Security Deposit.
- (v) If the Contractor fails to comply with the terms of these conditions, the Employer may insure the works and may deduct the amount of the premiums paid from any moneys that may be or become payable to the Contractor or may as an option, not release running payment to the Contractor till the Contractor shall have complied with the terms of this condition.

- (vi) Such insurance, whether effected by the Employer or the Contractor will not limit or bar the liability and obligation of the Contractor to deliver works to the Employer complete in all respects according to the contract. In case of loss or damage due to any of the aforesaid causes the moneys payable under any such insurance shall be received and retained by the Employer until the works are finally completed and such moneys shall then be credited to the Contractor in final settlement of accounts.

#### **6.2 Firm Price Contract:**

Prices quoted by the Contractor shall be firm. **No escalation in prices shall be payable on any account, whatsoever except in case of reinforcement steel** wherein any variation beyond +/- 5% of the base rate mentioned shall be payable to or recoverable from the bills due to the contractor. The contractor shall furnish documentary proof of steel procurement bills for all batches of steel consumed at the project to facilitate the above. Necessary store and/or ledger entries shall be maintained for verification.

6.3 If any ambiguity arises to the meaning and intent of any portion of specifications and drawings or to the execution or quality of any work or material or as to the measurement of the works, Employer shall have the power to correct any errors, omissions or discrepancies in the Specifications, Drawings, classification of the work or materials and whose decision in the matter shall be final and conclusive. In case of discrepancy between schedule of quantities, Specifications and/or drawings, the following order of preference shall be observed:

- (i) Description of items in the Schedule of quantities.
- (ii) Technical Specifications and Special Conditions of Contract.
- (iii) Working Drawings.
- (iv) C.P.W.D. Specifications
- (v) P.W.D. Specifications
- (vi) Indian Standard Specifications
- (vii) General Conditions of Contract

**6.4 The contractor shall have to work in close co-ordination with the other Contractors who are being appointed separately for carrying out related works for the Design, Supply, Installation, Testing & Commissioning of 100 kWp on Grid Connected Roof Top Solar PV (Photo Voltaic) Power Plant on the terrace of Senior School at Mayoor School, Ajmer.**

## SECTION – 7 TECHNICAL SPECIFICATION

### Name of the work

Design, Supply, Installation, Testing, Commissioning & Net Metering of 100 kWp Grid connected roof top solar PV(photo voltaic) power plant.

### Scope of Work

**Design the system as per the available area to maximize the generation.**

**Supply the material as per the specifications and design.**

**Installation of the systems as per the described proper methodology.**

**Commissioning of the system as per the applicable latest standard and grid code.**

### 7. Introduction

- a. In grid-connected solar photo-voltaic (PV) systems, solar energy is fed into the building loads that are connected to the discom grid through a service connection with surplus energy being fed into the grid and shortfall being drawn from the grid. Production of surplus energy may happen when solar energy produced exceeds the energy consumption of the building. This surplus is fed into the grid. During the night, or when during the day energy demand in the building exceeds solar energy generation, energy is drawn from the grid. Grid-connected solar PV systems have no battery storage and will not work during grid outage. For buildings with grid-connected solar PV systems, the service connection meter needs to be of the bidirectional type, whereby import kWh and export kWh are separately recorded.
- b. A grid-connected solar PV system consists of the solar panels, solar panels' mounting structure, one or more solar grid inverters, protection devices, meters, inter-connection cables and switches.
- c. Components and parts used in solar PV systems should conform to the BIS or IEC or other international specifications, wherever such specifications are available and applicable.

### 7.2. Quality and Workmanship

- a. Solar PV modules are designed to last 25 years or more. It is therefore essential that all system components and parts, including the mounting structures, cables, junction boxes, distribution boxes and other parts also have a life cycle of at least 25 years. Therefore all works shall be undertaken with the highest levels of quality and workmanship. During inspection special attention will be given to neatness of work execution and conformity with quality and safety norms. Non-complete works will have to be redone at the cost of the Installer.

### 7.3. Certification:

#### PV Modules

PV Modules IEC 61215 / I S14286. In addition, the modules must conform to IEC 61730 Part 1- requirements for construction & Part 2 - requirements for testing, for safety qualification or Equivalent IS. PV modules shall be suitable to be used in a highly corrosive atmosphere (coastal areas, etc.) and must qualify Salt Mist Corrosion Testing as per IEC 61701 / IS 61701.

## **BALANCE OF SYSTEM (BOS) ITEMS/ COMPONENTS**

The BOS items / components of the SPV power plants/ systems deployed under the contract must conform to the latest edition of IEC/ Equivalent BIS Standards/ MNRE specifications / as specified below:

<b>BOS Item /System</b>	<b>Applicable BIS /Equivalent IEC Standard Or MNRE Specifications</b>	
	Standard Description	Standard Number
Solar Inverter	Environmental Testing	IEC 60068-2 (1,2,14,30) / Equivalent BIS Std.
Solar Inverter	Efficiency Measurements	IEC 61683 / IS 61683
Inverters and Protections	Environmental Testing	IEC 60068-2 (1, 2, 14, 30) / Equivalent BIS Std. IEC 62116
Cables	General Test and Measuring Method XLPE insulated cables for working voltage up to and including 1100 V and UV resistant for outdoor Installation	IEC 60227 / IS 694 IEC 60502 / IS 1554 (Pt. I & II)
Switches/Circuit Breakers/Connectors	General Requirements Connectors –safety A.C. /D.C.	IEC 60947 part I,II, III / IS 60947 Part I,II,III EN 50521
Junction Boxes Enclosures for Inverters/Charge Controllers/Luminaries	General Requirements	IP 65(for outdoor)/ IP21(for indoor) as per IEC 529

### **7.4. Specification of Solar PV Modules**

- a. Solar PV modules shall be of the crystalline silicon type, manufactured in India. Detailed specifications of the solar PV modules are given below:

<i>Type</i>	Bi Facial Mono crystalline silicon ( N Type)
<i>Efficiency</i>	>= 20%
<i>Degradation warranty</i>	Panel output (Wp) capacity to be >=97% of design nominal power after one year and >=85% of design nominal power after 25years.
<i>Module frame</i>	Non-corrosive and electrolytic ally compatible with the mounting structure material
<i>Termination box</i>	Thermo-plastic, IP 65, UV resistant

<i>Module minimum rated power</i>	The nominal power of a single PV module shall not be less than <b>540 Wp.</b>
<i>RF Identification tag for each solar module</i>	Shall be provided inside the module and must be able to withstand environmental conditions and last the lifetime of the solar module.
<i>RF Identification tag data</i>	3.1 Name of the manufacturer of PV Module 3.2 Name of the Manufacturer of Solar cells 3.3 Month and year of manufacture (separately for solar cells and module) 3.4 Country of origin (separately for solar cells and module) 3.5 I-V curve for the module 3.6 $W_m$ , $I_m$ , $V_m$ and FF for the module 3.7 Unique Serial No and Model No of the module 3.8 Date and year of obtaining IEC PV module qualification certificate 3.9 Name of the test lab issuing IEC certificate 3.10 Other relevant information on traceability of solar cells and module as per ISO 9000 standard
<i>Power output rating</i>	To be given for standard test conditions (STC). I-V curve of the sample module shall be submitted.
<i>Compliance with standards and codes</i>	IEC 61215 / IS 14286 IEC 61730 Part 1 and 2
<i>Salt Mist Corrosion Testing</i>	As per IEC 61701
<i>Modules shall be PID (potential induced degradation) resistant.</i>	<i>IEC 61215</i>

#### 7.5. **Solar PV Modules Mounting Structure**

- a. The PV modules shall be mounted on fixed metallic structures having adequate strength and appropriate design, which can withstand the load of the modules and high wind velocities as required (up to 150 Km/Hr). The support structure shall be hot dip galvanized steel of adequate cross section of channels and angles. The detail drawing of the structure to be approved by the Engineer in charge prior to the execution of work. No grouting of the support structure to an existing terrace will be allowed to protect the integrity of the water proofing. In case grouting is required then the detail and the execution for the same shall be given prior to the waterproofing of the terrace.
- b. **Detailed specifications for the mounting structure are given below:**

<i>Structure material</i>	Hot dip galvanized steel with a minimum galvanization thickness of 80 microns (or aluminum alloy). The detail drawings of the structure with sizes of GI channels/angles are required to be got approved from the Engineer- in-charge prior to the execution of work at site.
<i>Bolts, nuts, fasteners, panel mounting clamps</i>	Stainless steel SS 304



<i>Mounting arrangement for RCC-flat roofs</i>	Suitable number of PV Panel Structure with I, C or L-Sections. Structure material will be Hot Dip galvanized with minimum 80 microns thickness. Columns will be suitably located on the terrace with suitable foundations, overall structure to withstand minimum 150km/hr wind speed.
<i>Installation</i>	The structures shall be designed for simple mechanical on-site installation. There shall be no requirement of welding or complex machinery at the installation site.
<i>Minimum distance between roof edge and mounting structure</i>	0.3m
<i>Access for panel cleaning and maintenance</i>	All solar panels must be accessible from the top for cleaning and from the bottom for access to the module- junction box.
<i>Panel tilt angle</i>	As per the maximum generation.

- c. The prospective Installer shall specify installation details of the solar PV modules and the support structures with lay-out drawings and array connection diagrams. The work shall be carried out as per the designs approved by the Customer.

#### 7.6. **Power Optimiser**

Power Optimiser DC / DC Converter with constant string voltage feature and which is connected to each PV Module (upto 0.5kWp) Or only one for every 2 PV Modules (  $\geq 1\text{kWp}$ ) to provide individual module level Maximum Power Point Tracking (MPPT) for mitigating all types of modules mismatch-loss, manufacturing tolerances and partial shading. Power Optimiser should also be capable for advanced, real time performance measurement. Optimiser to be able to instantaneously clamp DC Voltage to 1V DC (Safe DC) per optimizer when AC power is shut off for installer and firefighter safety and having technical specification as mentioned below:

S.No.	Description		Single PV Optimiser	Dual PV Module Optimiser
1	Suitable for	:	72-cell SPV Modules	
2	Module Power :		$\geq 540\text{W}$	$\geq 1180\text{W}^*$
3	Module Voc	:	As per N type Bi Facial Panels	
4	MPPT Operating Range	:	As per N type Bi Facial Panels	

5	Maximum DC Input Current	:	15A	15A
6	Maximum Efficiency	:	99.5%	
7	Maximum Output Current	:	15 Adc	
8	Maximum Output Voltage	:	<=80 Vdc	<=80 Vdc
9	Safety Output Voltage per Power Optimiser	:	1 VDC	
10	Maximum Allowed System Voltage	:	1000 VDC	
11	Input Connector	:	MC4 Compatible	
12	Protection Rating	:	IP68	
13	Total Strings Size	:	Minimum Power per string 15.6kWp	Yes, Maximum Power per string 32.4kWp
14	Warranty	:	25 years reliability and warranty	
15	Compliance	:	<b>EMC:</b> FCC Part 15 Class B, IEC61000-6-2, IEC61000-6-3 <b>Safety:</b> IEC62109-1 (Class II Safety ), UL1741 <b>Fire Safety:</b> VDE-AR-E 2100-712:2013-05	<b>EMC:</b> FCC Part 15 Class B, IEC61000-6-2, IEC61000-6-3 <b>Safety:</b> IEC62109-1 (Class II Safety ), UL1741 <b>Material:</b> UL-94 (5-VA), UV resistant
*Rated combined STC power of 2 modules connected in series. Module of upto +5% power tolerance allowed				

### 7.7. **Solar Inverters**

Solar Inverters are the most critical equipment in the Solar PV plant, as the reliability & performance of the inverters have great influence on the plant overall performance & availability. The contractor shall plan String Inverter suitable to feed different AC power to MDB in the manufacturing Plant. Solar Grid-Tie String Inverters with DC Safety unit (having specification as per S.No. 2.2). The Grid Tie Inverter should be designed to work with Power Optimizers Module Level MPPT ( Maximum Power Point Tracking ) providing constant string voltage and should have anti-islanding feature. Inverter should have the specifications as mentioned below:

<b>27.6kVA Grid-Tie String Inverter</b>				
1	Maximum Input Voltage	:	1000 Vdc	
2	Operating Voltage range	:	680-1000 Vdc	
3	Fixed Voltage Range	:	750 Vdc	
4	Maximum Input current	:	80 Amp	
5	Maximum DC Power (Module STC)	:	1.20:1.0	
6	Reverse Polarity protection	:	Yes	
7	Connection type	:	3 Pairs MC4	
8	Rated AC Power Output	:	100 kVA	

9	Maximum AC Power Output	:	100 kVA
10	Maximum Continuous Output Current (per phase)	:	40 Amp
11	AC Output Voltage – Line to Line / Line to Neutral (Nominal)	:	380 / 220, 400 / 230V
12	Output Frequency	:	50/60 Hz +/- 5 Hz
13	Peak Efficiency	:	>=98%
14	Euro Efficiency	:	>=97.7%
15	Product Warranty	:	Standard 12-year warranty (extendable to 20 or 25 years)
16	Degree of protection	:	IP65
17	Operating temperature	:	-20 to +60°C
18	Noise Level	:	< 55 dbA
19	Night time consumption	:	< 4W
20	Supported Communication Interfaces	:	RS485, Ethernet, Zigbee /Wi-Fi / GSM (Optional)
21	Compliance	:	I. <b>Safety:</b> IEC-62103 (EN50178), IEC-62109, AS3100 II. <b>Grid Connection Standards:</b> VDE-AR-N-4105, G59/3, AS-4777, EN 50438, CEI-021, VDE 0126-1-1 III. <b>Emissions:</b> IEC61000-6-2, IEC61000-6-3, IEC61000-3-11, IEC61000-3-12

#### 7.8. **SPV Monitoring System**

- a. PV Monitoring system which should be capable of communicating with each individual PV Module through the solar inverter to provide module level real time monitoring (web and mobile) for 25 years to display the below mentioned parameters / Features

1	Should track the technical and financial performance of one or more PV Systems
2	Should provide API Interface and integrate with customized software
3	Monitoring App to be easily available via web browser and mobile device App store for iOS & Play store for Android
4	To Map & Display Module array layout for each inverter
5	To provide logical and physical PV site visualization with real-time performance data for each individual module and for the whole system
6	Should supply the historical and aggregated data, comparative analysis, diagnostics and a guided root-cause fault analysis. All data should be logged and be able to be securely reviewed and analyzed at any time from any location
7	To provide generation and comprehensive reports on site's energy production, revenues and technical status
8	To provide immediate fault detection and trouble shooting, efficient maintenance management and site profitability analysis
9	Should have a configurable rule engine which automatically detects problems, issues status reports and sends alerts via e-mail
10	Should have remote fault analysis and servicing options

11	Provide the interactive charts and site layout make it easy for installers to ensure a system is functioning properly after installation
12	Have a playback feature which visualizes the harvested power of a site during a selected time fragment
13	Should have Kiosk display features for enabling to showcase the PV Site performance on a display in public spaces (like building lobbies)

**7.9. Control and Communication Gateway along with Sensors**

- a. Control and Communication Gateway has an interface that allows for controlling of the Grid-Tie Inverters power through Wireless connections & RS485 to Ethernet converter suitable for following sensor having the technical specification below:

S.No.	Descriptions	Electrical Output Range	Operating Temperature (°C / °F )	Degree of protection
1	Irradiance Sensor	(0-1.4V)	-20 to 70 / - 4 to 155	IP65

**7.10. DC Distribution Box.**

- a. A DC distribution box shall be mounted close to the solar grid inverter. The DC distribution box shall be of the thermo-plastic IP65 DIN-rail mounting type and shall comprise the following components and cable terminations:
- b. Incoming positive and negative DC cables from the DC Combiner Box;
- c. DC Fuse for each string will connected in positive terminal cable
- d. DC surge protection device (SPD), class 2 as per IEC 60364-5-53;
- e. Outgoing positive and negative DC cables to the solar grid inverter.
- f. DC fuse shall be installed inside the DC Distribution Box to protect the DC cable that runs from the DC Distribution Box to the Solar Grid Inverter.

**7.11. AC Distribution Box**

- a. An AC distribution box shall be mounted close to the solar grid inverter. The AC distribution box shall be of the thermo plastic IP65 DIN rail mounting type and shall comprise the following components and cable terminations:
- b. Incoming 4 core (single-phase/three-phase) cable from the solar grid inverter
- c. AC circuit breaker, 2-pole/4-pole
- d. AC surge protection device (SPD), class 1 plus 2 as per IEC60364-5-53
- e. Outgoing cable to the building electrical distribution board.

**7.12. Cables**

- a. All cable shall be supplied conforming to IEC60227/IS694&IEC60502/IS1554. Voltagerating: 1,100V- AC, 1,500V-DC
- b. For the DC cabling, XLPE or XLPO insulated and sheathed, UV stabilised single core flexible copper cables shall be used. Multi-core cables shall not be used.
- c. For the AC cabling, XLPE insulated, and PVC sheathed single or multi-core flexible copper cables shall be used. Outdoor AC cables shall have a UV-stabilised outer sheath.
- d. The total voltage drop on the cable segments from the solar PV modules to the solar grid inverter shall not exceed 2.0%.
- e. The total voltage drop on the cable segments from the solar grid inverter to the building distribution board shall not exceed 2.0%.
- f. The DC cables from the SPV module array shall run through perforated galvanised slotted covered MS cable trays with perforation not more than 17.5% with all fixing arrangements on floor / wall / ceiling of suitable size (min. 300mm x 50mm x 1.6mm)
- g. Cables and wires used for the interconnection of solar PV modules shall be provided with solar PV connectors (MC4) and couplers.
- h. All cables and cable trays shall be clamped to the walls and ceilings with thermo-plastic clamps at intervals not exceeding 50 cm. Cable trays running on the terrace shall be kept clear of the terrace with of suitable studs so as to not impede the flow of rainwater. The minimum DC cable size shall be 4.0sq.mm copper. The minimum AC cable size shall be 4.0sq.mm. Copper.

- i. AC cable output from the inverter shall be taken to the main panel room of the school into a Solar AC Distribution Panel (required incoming Breakers (suitable rating) as per the number of inverters installed on one bus bar and an outgoing MCCB (125A) . Output cable from this breaker (of Solar ACDB) to be connected to the Customer LT Panel feeder. The contractor should ascertain the length and suitable size required the same.
- j. In three phase systems, the size of the neutral wire size shall be equal to the size of the phase wires. The following colour coding shall be used for cable wires:
  - 1. DC positive: red (the outer PVC sheath can be black with a red line marking)
  - 2. DC negative: black
  - 3. AC single phase: Phase: red; neutral:black
  - 4. AC three phase: Phases: red, yellow, blue; neutral: black
  - 5. Earth wires: green
- k. Cables and conduits that have to pass through walls or ceilings shall be taken through a UPVC pipe sleeve.
- l. Cable conductors shall be terminated with tinned copper end-ferrules to prevent fraying and breaking of individual wire strands. The termination of the DC and AC cables at the Solar Grid Inverter shall be done as per instructions of the manufacturer, which in most cases will include the use of special connectors.

#### 7.13. **Earthing**

- a. The PV module structure components shall be electrically interconnected and shall be grounded.
- b. Earthing shall be done in accordance with IS 3043-1986, provided that earthing conductors shall have a minimum size of 10.00 sq.mm. copper or aluminum 25 x 3 mm flat. Sleeves to be provided for the earth conductors in underground connections to earth electrodes.
- c. A minimum of three separate dedicated and inter connected earth electrodes must be used for the earthing of the solar PV system support structure with a total earth resistance not exceeding 5 Ohm.
- d. The earth electrodes shall have a precast concrete enclosure with a removable lid for inspection and maintenance. The entire earthing system shall comprise non-corrosive components.

#### 7.14. **Surge Protection**

- a. Surge protection shall be provided on the DC side and the AC side of the solar system.
- b. The DC surge protection devices (SPDs) shall be installed in the DC distribution box adjacent to the solar grid inverter.
- c. The AC SPDs shall be installed in the AC distribution box adjacent to the solar grid inverter.
- d. The SPDs earthing terminal shall be connected to earth through the above mentioned dedicated earthing system. The SPDs shall be of type 2 as per IEC60364-5-53

#### 7.15. **Junction Boxes**

- a. Junction boxes and solar panel terminal boxes shall be of the thermo plastic type with IP 65 protection for outdoor use and IP 54 protection for indoor use.
- b. Cable terminations shall be taken through thermo-plastic cable glands. Cable ferrules shall be fitted at the cable termination points for identification.

#### 7.16. **Tools, Tackles and Spares**

- a. The Installer shall keep ready stock of tools, tackles and essential spares that will be needed for the day-to-day maintenance of the solar PV system. This shall include but not be limited to the following:
  - b. Screw driver suitable for the junction boxes and combiner boxes
  - c. Screw driver and / or Allen key suitable for the connectors, power distribution blocks, circuit breaker terminals and surge arrester terminals;
  - d. Spanners / box spanners suitable for the removal of solar PV modules from the solar PV module support structure;
  - e. Solar panel mounting clamps;

- f. Cleaning tools for the cleaning of the solar PV modules;
- g. Spare fuses.
- h. Digital Meter for measuring Various Different AC-DC values & for identifying faults.

#### 7.17. **Caution Signs**

- a. In addition to the standard caution and danger boards or labels as per Indian Electricity Rules, the AC distribution box near the solar grid inverter, the building distribution board to which the AC output of the solar PV system is connected and the Solar Generation Meter shall be provided with a non-corrosive caution label with the following text:
- b. The size of the caution label shall be 105mm (width) x 20mm (height) with white letters & red at the background.

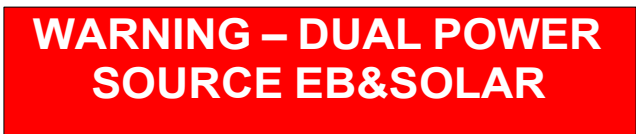

- c. Caution labels as may be prescribed by as per DISCOM specifications.

#### 7.18. **Metering**

An energy meter shall be installed in between the solar grid inverter and the building distribution board to measure total solar AC energy production (the "Solar Generation Meter"). The Solar Generation Meter shall be of the same accuracy class as the DISCOM service connection meter or as specified by DISCOM. The successful bidder has to take all relevant approval and certification from DISCOM along with supply of the Net Metering

#### 7.19 **Test Certificates and Reports to be furnished.**

Test Certificates / Reports from IECQ / NABL accredited laboratory for relevant IEC / equivalent BIS standard for quoted components shall be furnished. Type Test Certificates shall be provided for the solar modules and the solar grid inverters to provide evidence of compliance with standards as specified above in this Technical Specification. Customer reserves the right to ask for additional test certificates or (random) tests to establish compliance with the specified standards.

#### 7.20 **Integration Of PV Power With Grid & DG**

The output power from SPV would be fed to the inverters which convert DC produced by SPV array to AC and feeds it into the main electricity grid after synchronization. In case of grid failure, or low or high voltage, solar system shall be out of synchronization and shall be disconnected from the grid. Once DG is operated, Solar will be synchronised with the same with the use of DEIF ASC Controllers and AGC (Generator Controller) to synchronise working of Solar, Grid and DG. Both existing Solar Plant of 200kWp and new plant will be synchronised with Grid and 2 DG Sets of 180 kVA and/or 125kVA.

#### 7.21 **Expected Electricity Generation**

The bidder has to submit an undertaking regarding minimum expected electrical energy generation (kWh). The bidder may indicate the guaranteed electrical energy generation from their system after making proper assessment.

#### 7.22 **Project Completion Time**

The successful bidder will submit detail schedule for the execution of the project in a period of 3 months on availability of site for construction. Delay in completion will attract a penalty of 0.1% of the contract value per week.

#### 7.23 **Comprehensive Maintenance**

The successful bidder will provide a Comprehensive Maintenance Service for a period of 1 year from the date of commissioning of the Solar Plant. An option for providing AMC service will be given from 2<sup>nd</sup> year onwards. First year CMC will cover resolution of any breakdown within a period of 48 hours from the time of intimation. Any replacement of parts covered within warranty will be the responsibility of the bidder for the 1<sup>st</sup> year. Also minimum plant downtime will be intimated and schedule adhered to in the 1<sup>st</sup> year of Maintenance by the successful bidder. This will be calculated basis availability of grid conditions (which can be pre defined for a Grid-Tied PV Solar plant)

#### 7.24 **Annexe to General Technical Specification**

Typical wiring diagram for grid-connected solar PV system *with* diesel generator.

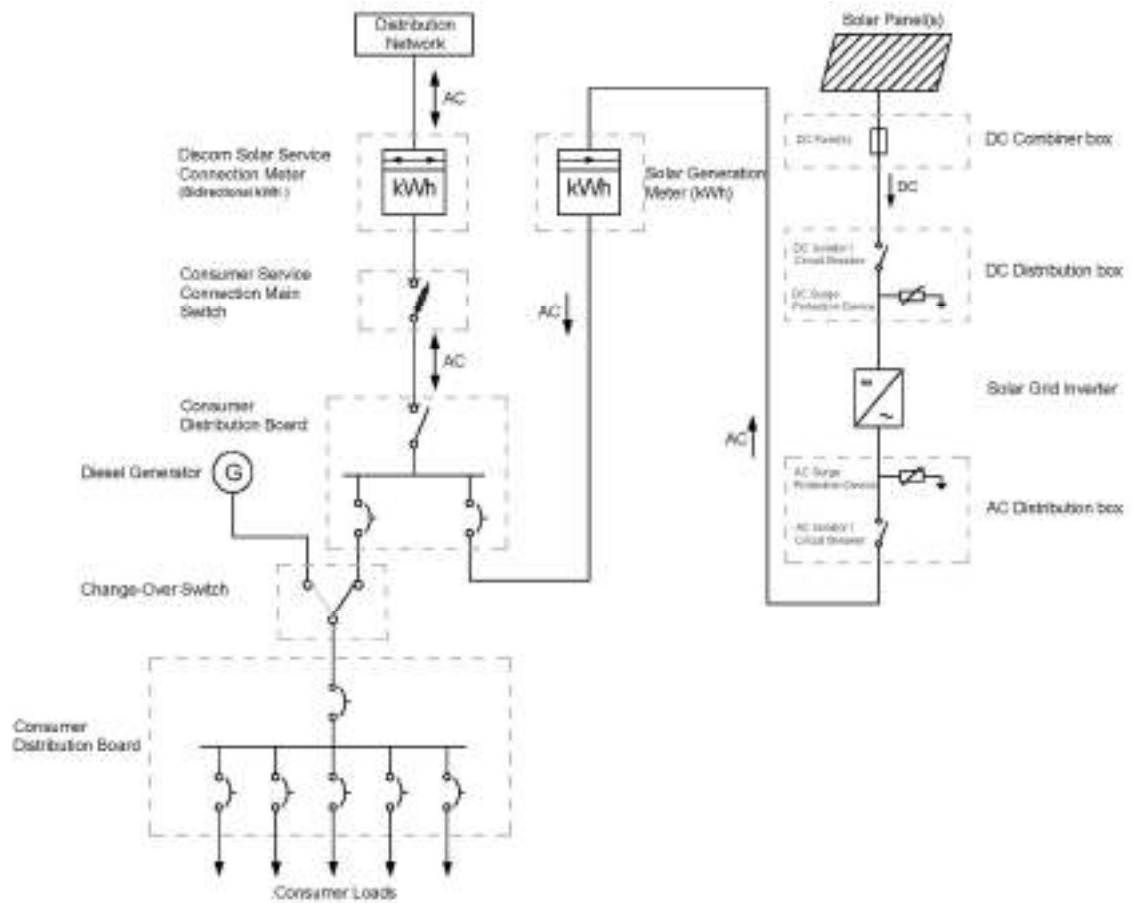

**Note:** The Solar Generation Meter shown above is mandatory for consumers who avail of a generation-based incentive (GBI) and is optional for others.

## 7.25 List of Main Equipment and Approved Make Lists:

List of Item	Capacity	Preferred Vendor
Solar PV panel	Each panel shall be minimum 540 WP	Vikram/Adani/Waaree/Jinko/Trina/Longi with valid IEC certificates
Inverter	Each inverter shall be minimum of 50kVA and AC – DC ratio should be minimum 1:1	SMA / SolarEdge (Preferably)
Structure	Shall be made with IS compliance	Industry Standard & As per the specifications
AC / DC cables	Shall be as per the specifications	Havells/LAPP/Polycab Equivalent Shall be with valid IEC, reputed
DC combiner box & Accessories	Shall be as per the specifications	Junction Box: Ensto/Equivalent.  MC4-Connector: Elmex/Kripson/Equivalent;  SPD: Citel/OBO/Betterman/Equivalent
AC distribution box& Accessories	As per the specification	Junction Box: Ensto/ Reputed Equivalent.  MCCB-ABB/legrand/Havells/ Reputed Equivalent,  SPD- Citel/OBO/Betterman/ Reputed Equivalent
Surge Protection Device	As per the specification	Citel/OBO/Betterman/Equivalent Reputed
Meter	As per the specification	L&T /Equivalent Reputed
Earthing	As per the specification: Chemical	Shakti/OBO/Betterman/Equivalent Reputed
Solar & DG Sync Controllers		DEIF or equivalent



**7.26 Specific makes & details.**

(To be filled by the bidder & hard copies to be provided for evaluation purpose)

<b>List of Item</b>	<b>Unit</b>	<b>Size</b>	<b>Make</b>	<b>Warranty</b>	<b>Total Capacity</b>
<b>i.</b> Solar PV panel (please mention Poly or Mono Chrystalline)					
<b>ii.</b> Area Required for Panel Installation					
<b>iii.</b> Inverter					
<b>iv.</b> Structure					
<b>v.</b> Room area required for installation of string inverters					
<b>vi.</b> DC cables: Array to Array:					
<b>vii.</b> DC cables Aray to Array JB or DC combiner box					
<b>viii.</b> DC cables from DC combiner box to Inverter					
<b>ix.</b> AC cable from Inverter to ACDB					
<b>x.</b> AC cable from ACDB to Grid					
<b>xi.</b> Earthing Cable or wire from Panel Structure to Earth					
<b>xii.</b> Earthing Cable or wire from DC combiner box to to Earth					
<b>xiii.</b> Earthing Cable or wire from Inverter to to Earth					
<b>xiv.</b> DC combiner box					
<b>xv.</b> AC distribution box (ACDB)					
<b>xvi.</b> Surge Protection Device					
<b>xvii.</b> Meter					
<b>xviii.</b> Earthing					

## **7.27 Specifications**

(To be filled by the bidder & hard copies to be provided for evaluation purpose)

- a) Specification of Solar PV Modules
- b) Solar PV Modules Mounting Structure
- c) Solar Array Fuse
- d) Solar Grid Inverter:
- e) DC Combiner Box
- f) DC Distribution Box if any.
- g) AC Distribution Box
- h) Connection to the Building Electrical System
- i) Cables
- j) Earthing
- k) Surge Protection
- l) Junction Boxes
- m) Tools, Tackles and Spares
- n) Maximum response time on report of breakdown
- o) Terms for AMC beyond the first year

## APPENDIX SHOWING IMPORTANT SCHEDULES

1.	Signing Of Agreement	Within 7 days of issue of letter of intent / order (clause 1.8)
2.	Commencement Of Work	Immediately within seven days of issue of letter of intent / order (clause 5.3.1)
3.	Period Of Completion	75 days from date of issue of letter of intent / order (clause 1.1)
4.	Liquidated Damages	0.5% of Contract value per week subject to a maximum of 5% of the contract value (clause 5.2.26)
5.	Period Of Value Of Running/ On Account Bill	Monthly if not less than Rs.20.00 Lakhs (Clause 5.5.2 (i-v))
6.	Security Deposit	10% of the contract value. Recoveries will be made @ 10% from each Running Account / On Account Bill (Clause 5.2.18)
7.	Refund Of Security Deposit	1 <sup>st</sup> installment equal to 50% of the security deposit after three months of the virtual completion of the entire work. (clause 5.2.19(i)) 2 <sup>nd</sup> installment equal to 50% viz., balance of the security deposit after thirty days of expiry of defects liability period. (clause 5.2.19 (ii))
8.	Secured Advance	75% of the material brought to site for the express consumption in this project.
9.	Income Tax And Work Tax & Sales Tax Deduction	At prevailing rate from each bill.
10.	Defects Liability Period	12 months after completion of work (clause 5.5.5)
11.	Period Of Final Measurement	7 days after virtual completion of work. (clause 5.5.3)
12.	Rate for Extra, Additional or Altered or Substituted work	If the rates for altered, additional or substituted work cannot be determined in the manner specified in sub-clause 5.4.2 (i) and (ii), the rates for such items will be worked out on the basis of rates given in BSR 2013 Ajmer. The rates for additional, altered, and substituted work shall be paid as per BSR 2019 Jaipur @ ..... % above/below.

**MAYOOR SCHOOL**

**TENDER FOR**

DESIGN, SUPPLY, INSTALLATION, TESTING & COMMISSIONING  
OF 100 KWP ON GRID CONNECTED ROOF TOP SOLAR PV (PHOTO VOLTAIC)  
POWER PLANT AND NET METERING

VOLUME – II: BILL OF QUANTITIES

**CLIENT**

**MAYOOR SCHOOL, AJMER**

**ARCHITECTS**

**MR. VIJAY MATANGE**

**VINYAS**

Delhi

Email: [vinyas.arch@gmail.com](mailto:vinyas.arch@gmail.com)

**SECTION – 8**

**BILL OF QUANTITIES / TENDER SCHEDULE**

S. No.	Name of work	Tendered Value (in Rupees)
<b>1.0</b>	<b>Design, Supply, Installation, Testing, Commissioning &amp; Net Metering of 100 kWp on Grid Connected Roof Top Solar PV (Photo Voltaic) Power Plant on the terrace of Senior School at Mayoor School, Ajmer as per technical specifications listed in Section 7.</b>	
<b>2.0</b>	Add GST	
<b>3.0</b>	Total with GST	

**MAYOOR SCHOOL**

**TENDER FOR**

DESIGN, SUPPLY, INSTALLATION, TESTING & COMMISSIONING  
OF 100 KWP ON GRID CONNECTED ROOF TOP SOLAR PV (PHOTO VOLTAIC)  
POWER PLANT AND NET METERING

VOLUME – III: DIAGRAM

**CLIENT**

**MAYOOR SCHOOL, AJMER**

**ARCHITECTS**

**MR. VIJAY MATANGE**

**VINYAS**

Delhi

Email: [vinyas.arch@gmail.com](mailto:vinyas.arch@gmail.com)

Typical wiring diagram for grid-connected solar PV system *with* diesel generator.

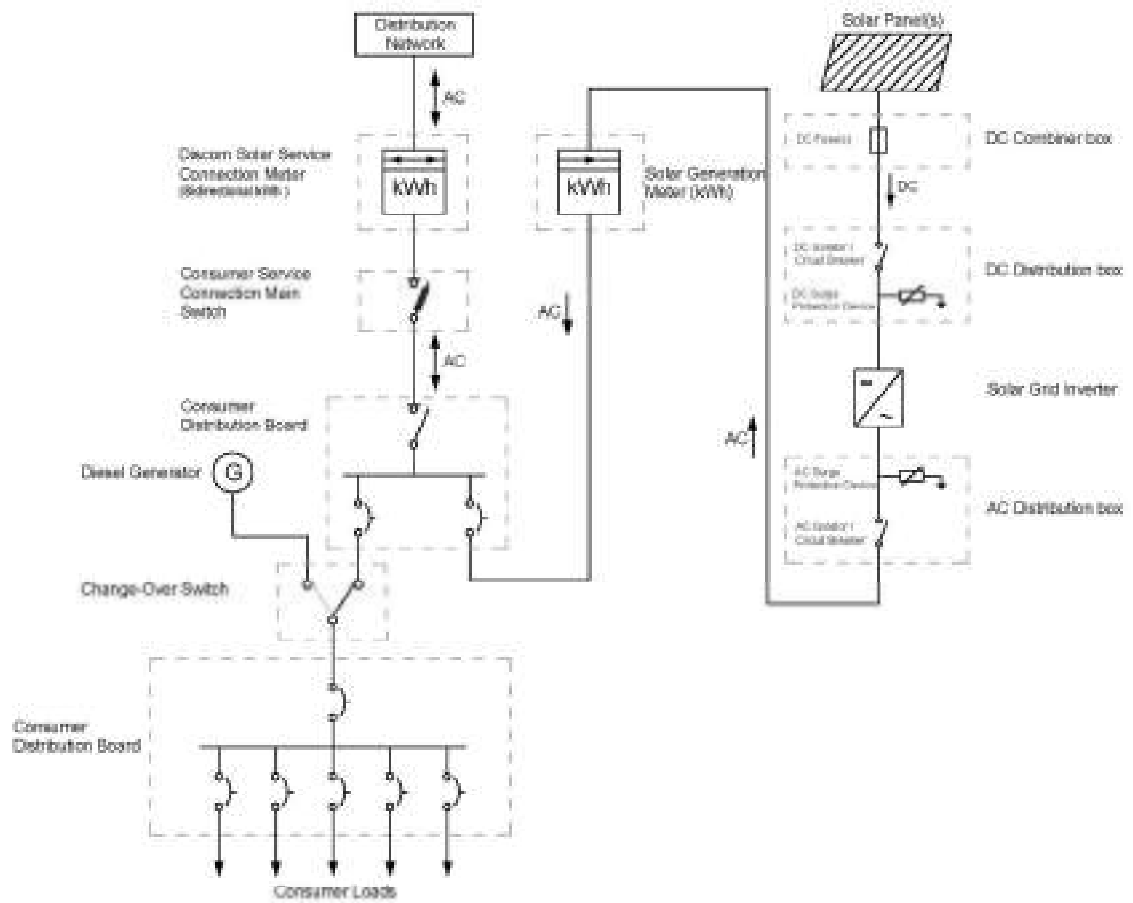

*Note:* The Solar Generation Meter shown above is mandatory for consumers who avail of a generation-based incentive (GBI) and is optional for others.

Plant Layout

